

REVISIONS									
LTR	ECO	APPD	DATE	DESCRIPTION	DFTR	DATE	CHKR	DATE	
D	.	.	.	CHG'D SECTION VIEW B-B & ADDED DIMS	SG	3/29/2005			

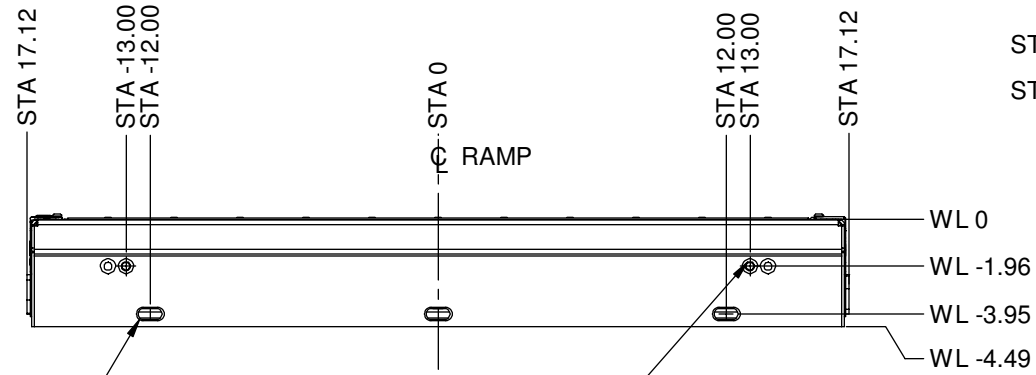

VIEW A-A

3x SLOT .438 x 1.00 FOR PERMANENT ATTACHMENT TO ROADSIDE VEHICLE MEMBER. VEHICLE MANUFACTURER TO PROVIDE VERTICAL ADJUSTMENT. SEE NOTE 2.

TWO CAPSCREWS FASTEN RAMP ASSEMBLY TO ROADSIDE SUPPORT CLOSEOUT. VEHICLE MANUFACTURER TO PROVIDE CLEARANCE IN ROADSIDE VEHICLE MEMBER. SEE NOTE 1 AND 2.

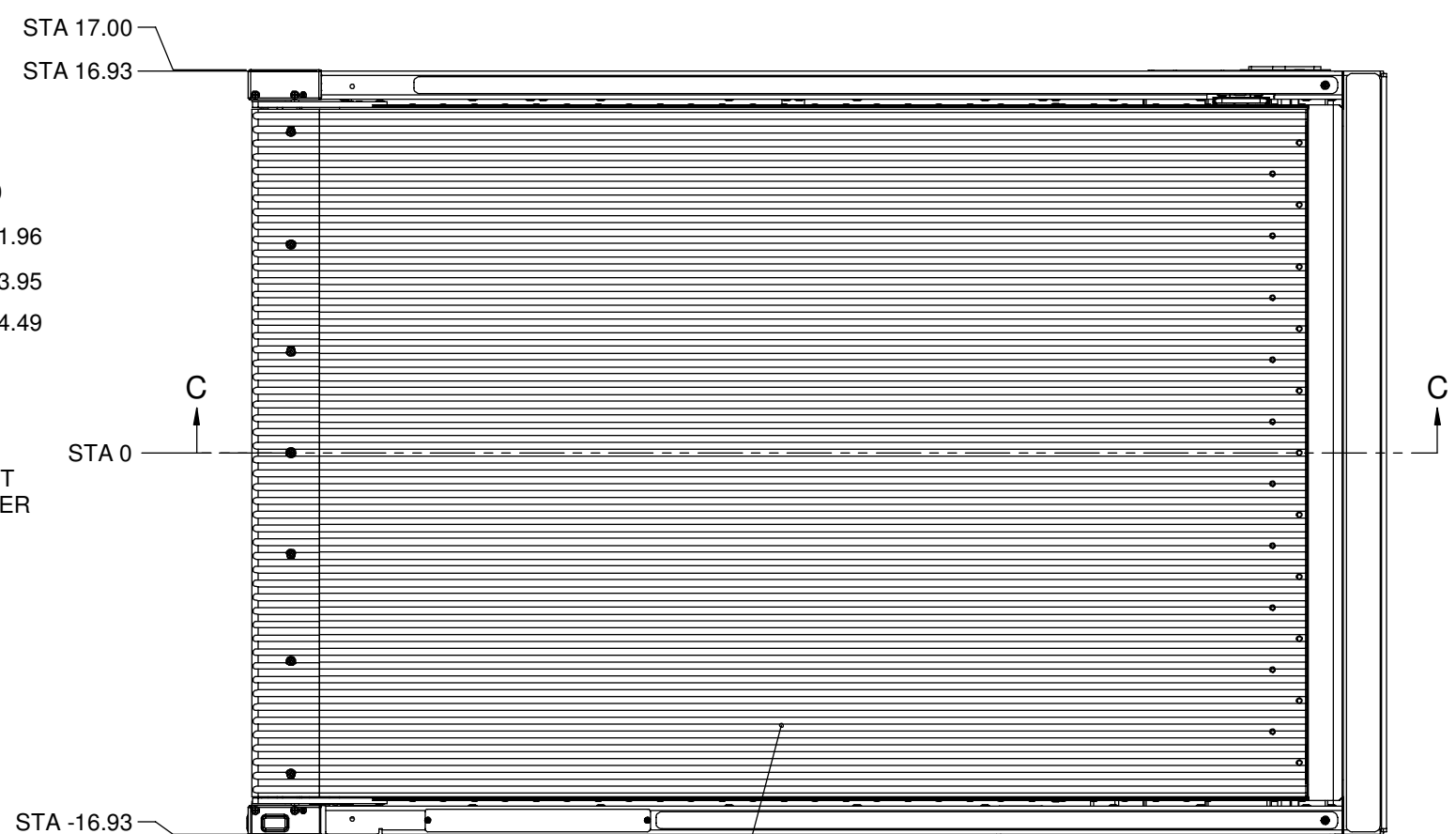

ELEVATION VIEW RAMP STOWED

TREAD SURFACE FLUSH WITH VEHICLE FLOOR

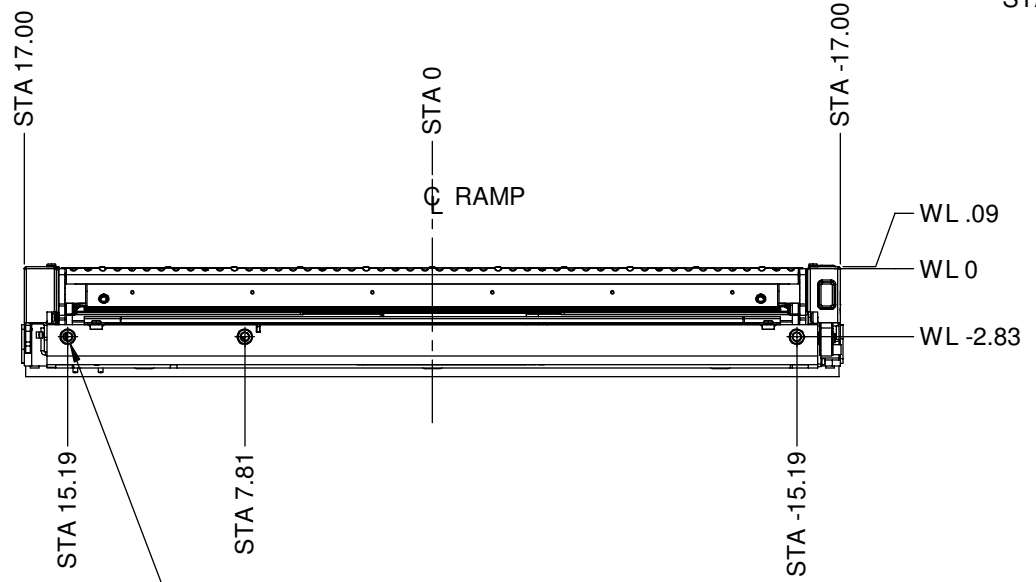

3x 3/8-24 TAPPED HOLES FOR ATTACHMENT TO CURBSIDE VEHICLE MEMBER. VEHICLE MANUFACTURER TO PROVIDE FOR VERTICAL AND HORIZONTAL ADJUSTMENTS.

 LIFT-U P.O. BOX 398 ESCALON, CA, 95320 209-838-2400	THIS DOCUMENT IS AND CONTAINS CONFIDENTIAL TRADE SECRET INFORMATION OF THE COMPANY. NO PART OF IT MAY BE REPRODUCED, STORED IN A RETRIEVAL SYSTEM, OR TRANSMITTED IN ANY FORM OR BY ANY MEANS ELECTRONICALLY, PHOTOCOPIING, RECORDING OR OTHERWISE, WITHOUT THE PRIOR WRITTEN PERMISSION OF HOGAN MFG, INC. THIS DOCUMENT IS LOANED FOR THE LIMITED PURPOSES STATED HEREIN ONLY, AND REMAINS THE PROPERTY OF THE COMPANY.	
	A DIVISION OF HOGAN MFG., INC.	
TITLE RAMP OPERATION/ENVELOPE		
DOCUMENT NO. 726-0003	SHEET NO. 1 OF 4	REVISION D

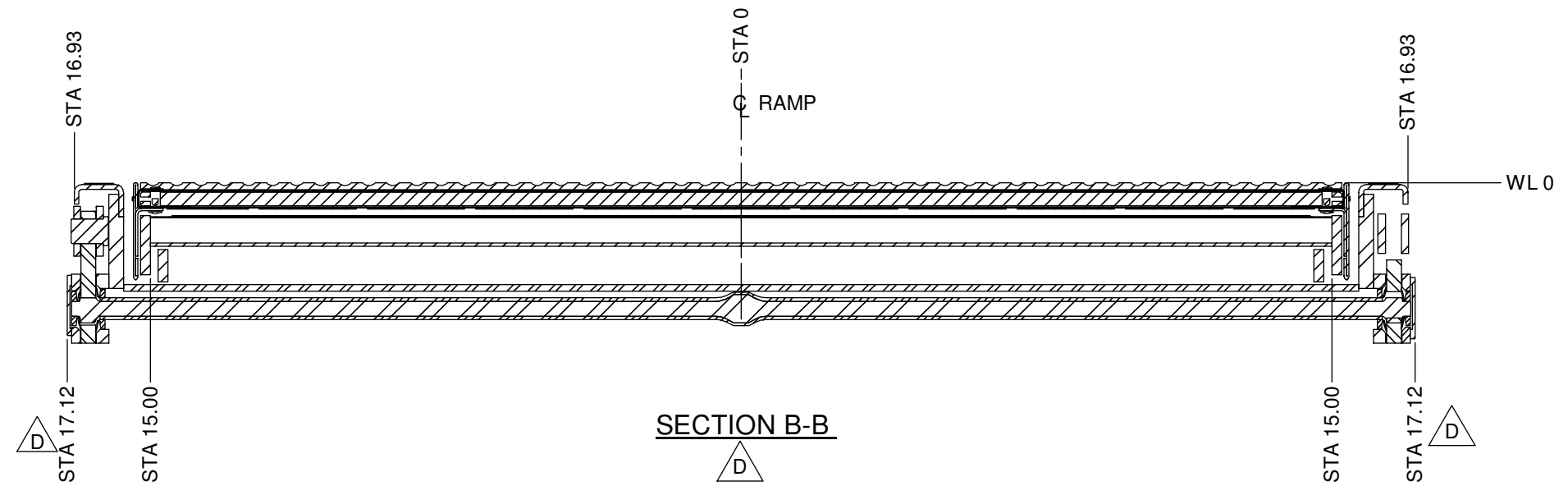

SECTION B-B

NOTES:

1. THE ROADSIDE SUPPORT CLOSEOUT IS FASTENED TO THE RAMP ASSEMBLY WITH TWO CAPSCREWS AT THE FACTORY.
2. THE ROADSIDE SUPPORT CLOSEOUT SHIPS ASSEMBLED TO THE RAMP. AT INSTALLATION THE ROADSIDE SUPPORT CLOSEOUT IS BOLTED TO THE ROADSIDE VEHICLE MEMBER AFTER THE RAMP ASSEMBLY HAS BEEN ADJUSTED FLUSH WITH THE VEHICLE FLOOR. VEHICLE MANUFACTURER TO PROVIDE VERTICAL ADJUSTMENT IN THE ROADSIDE VEHICLE MEMBER, AND VERTICAL AND HORIZONTAL ADJUSTMENT IN THE CURBSIDE VEHICLE MEMBER.
3. ONLY SIX FASTENERS NEED TO BE HANDLED FOR SUBSEQUENT REMOVAL AND REINSTALLATION OF THE RAMP ASSEMBLY. THREE CAPSCREWS EACH CURBSIDE AND ROADSIDE.
4. TOP OF "RCA" NOSING IS WL .03.
TOP OF "ALTRO" NOSING IS WL 0.

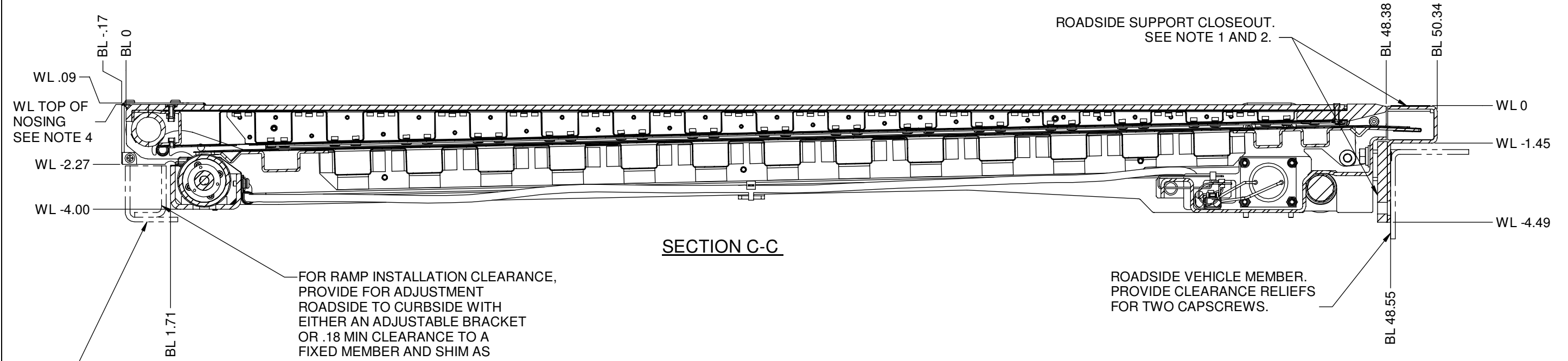

SECTION C-C

ROADSIDE SUPPORT CLOSEOUT.
SEE NOTE 1 AND 2.

ROADSIDE VEHICLE MEMBER.
PROVIDE CLEARANCE RELIEFS
FOR TWO CAPSCREWS.

FOR RAMP INSTALLATION CLEARANCE,
PROVIDE FOR ADJUSTMENT
ROADSIDE TO CURBSIDE WITH
EITHER AN ADJUSTABLE BRACKET
OR .18 MIN CLEARANCE TO A
FIXED MEMBER AND SHIM AS
REQUIRED. THIS CLEARANCE/
ADJUSTMENT MAY BE AT EITHER
THE CURBSIDE (SHOWN) OR
ROADSIDE

CURBSIDE VEHICLE MEMBER
BETWEEN DOOR POSTS

 LIFT-U P.O. BOX 398 ESCALON, CA, 95320 209-838-2400	THIS DOCUMENT IS AND CONTAINS CONFIDENTIAL TRADE SECRET INFORMATION OF THE COMPANY. NO PART OF IT MAY BE REPRODUCED, STORED IN A RETRIEVAL SYSTEM, OR TRANSMITTED IN ANY FORM OR BY ANY MEANS ELECTRONICALLY, PHOTOCOPIING, RECORDING OR OTHERWISE, WITHOUT THE PRIOR WRITTEN PERMISSION OF HOGAN MFG, INC. THIS DOCUMENT IS LOANED FOR THE LIMITED PURPOSES STATED HEREIN ONLY, AND REMAINS THE PROPERTY OF THE COMPANY.	
	A DIVISION OF HOGAN MFG., INC.	
TITLE RAMP OPERATION/ENVELOPE		
DOCUMENT NO. 726-0003	SHEET NO. 2 OF 4	REVISION D

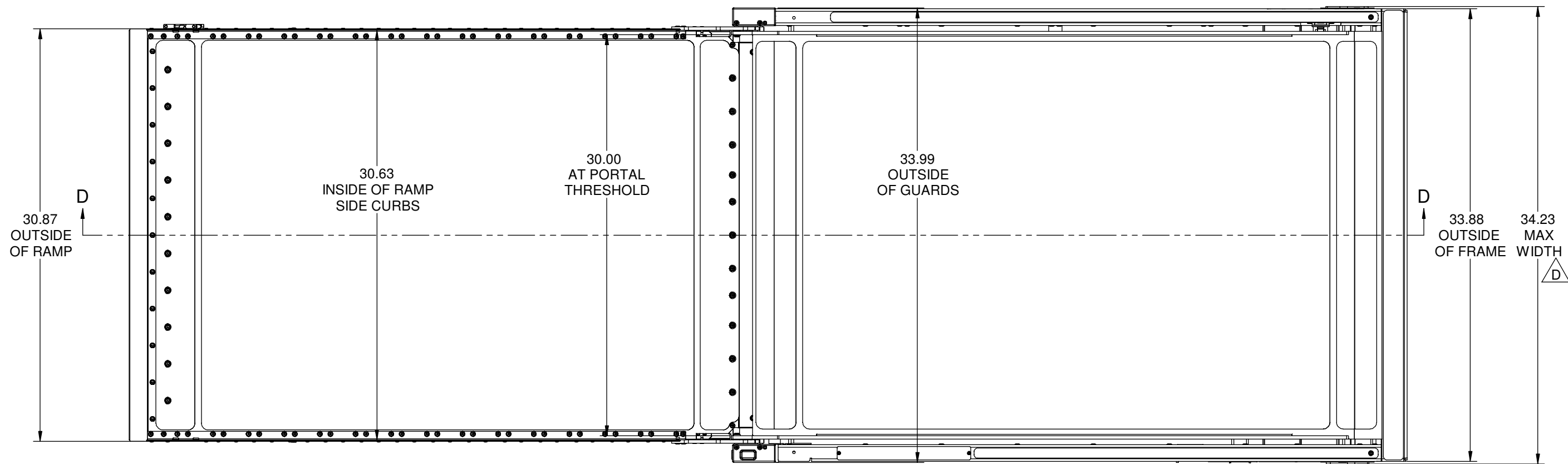

PLAN VIEW
RAMP DEPLOYED TO GROUND LEVEL

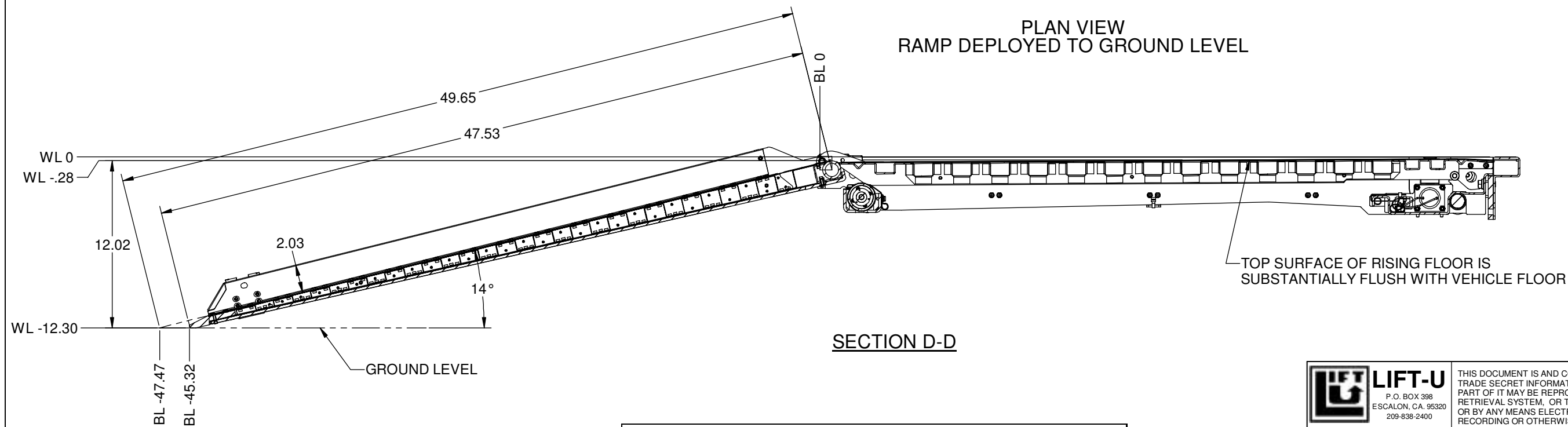

SECTION D-D

ADA RAMP SLOPE REQUIREMENTS FOR 12" STEP HEIGHT TO GROUND:		
STEP HT ABOVE 6" CURB	MAXIMUM RAMP SLOPE	MINIMUM RAMP LENGTH
> 3" TO 6"	1:6 (9.462 DEG.)	36.497"
> 6" TO 9"	1:8 (7.125 DEG.)	48.373"
MAX SLOPE TO GROUND	1:4 (14.036 DEG.)	49.477"



A DIVISION OF
HOGAN MFG., INC.

THIS DOCUMENT IS AND CONTAINS CONFIDENTIAL TRADE SECRET INFORMATION OF THE COMPANY. NO PART OF IT MAY BE REPRODUCED, STORED IN A RETRIEVAL SYSTEM, OR TRANSMITTED IN ANY FORM OR BY ANY MEANS ELECTRONICALLY, PHOTOCOPIING, RECORDING OR OTHERWISE, WITHOUT THE PRIOR WRITTEN PERMISSION OF HOGAN MFG, INC. THIS DOCUMENT IS LOANED FOR THE LIMITED PURPOSES STATED HEREIN ONLY, AND REMAINS THE PROPERTY OF THE COMPANY.

TITLE RAMP OPERATION/ENVELOPE

DOCUMENT NO. 726-0003

SHEET NO. 3 OF 4

REVISION D

TREAD SURFACE FLUSH WITH VEHICLE FLOOR

ISOMETRIC VIEW
RAMP STOWED

RAMP NON-SKID SURFACE

RISING FLOOR
NON-SKID SURFACE

ISOMETRIC VIEW
RAMP DEPLOYED TO GROUND LEVEL



LIFT-U
P.O. BOX 398
ESCALON, CA, 95320
209-838-2400

A DIVISION OF
HOGAN MFG., INC.

THIS DOCUMENT IS AND CONTAINS CONFIDENTIAL
TRADE SECRET INFORMATION OF THE COMPANY. NO
PART OF IT MAY BE REPRODUCED, STORED IN A
RETRIEVAL SYSTEM, OR TRANSMITTED IN ANY FORM
OR BY ANY MEANS ELECTRONICALLY, PHOTOCOPYING,
RECORDING OR OTHERWISE, WITHOUT THE PRIOR
WRITTEN PERMISSION OF HOGAN MFG, INC.
THIS DOCUMENT IS LOANED FOR THE LIMITED
PURPOSES STATED HEREIN ONLY, AND REMAINS
THE PROPERTY OF THE COMPANY.

TITLE **RAMP OPERATION/ENVELOPE**

DOCUMENT NO. **726-0003**

SHEET NO.
4 OF 4

REVISION
D