

REVISIONS						
REV	ECO	DESCRIPTION	CREATED	DATE	APPROVED	DATE
A		RELEASED	WAC	3-11-14		

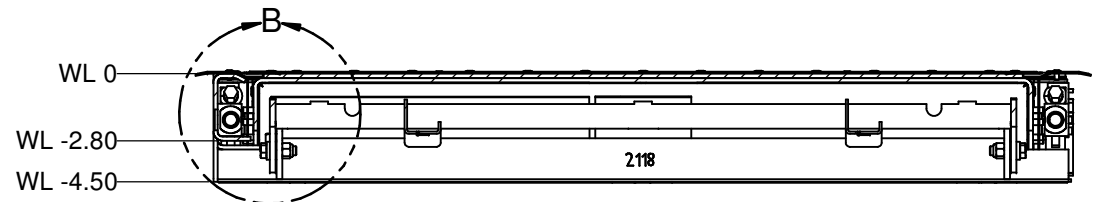

SECTION A-A

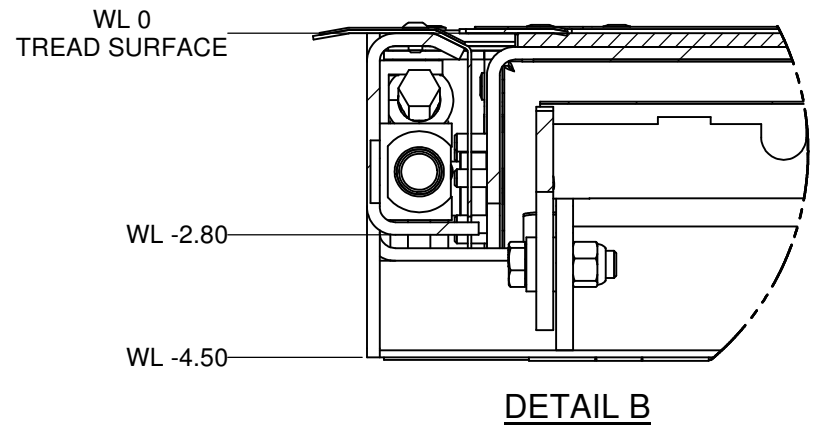
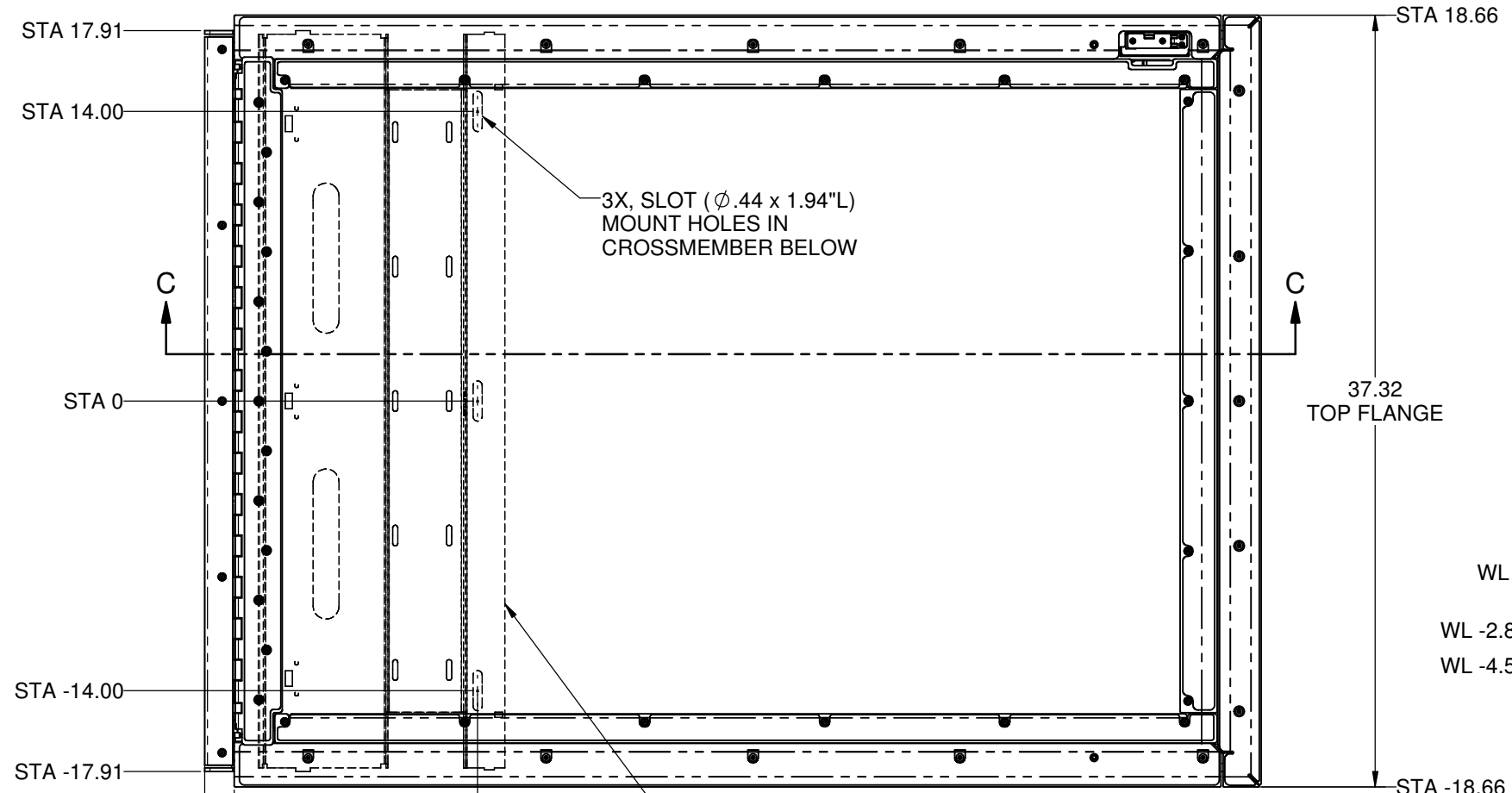
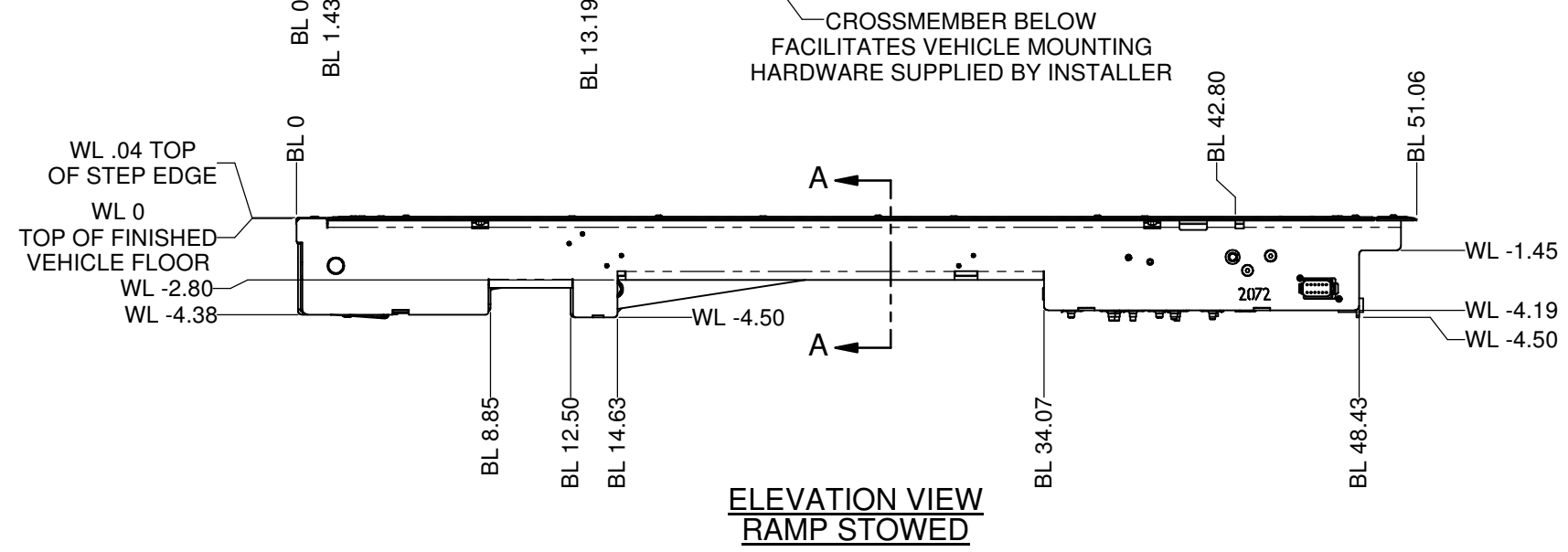

ELEVATION VIEW RAMP STOWED

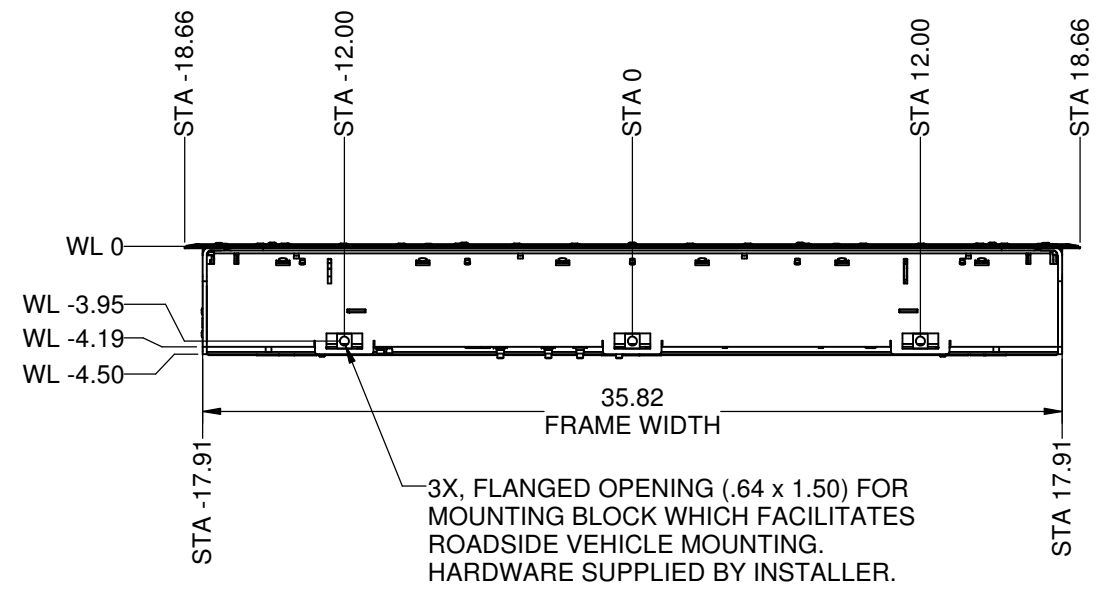

RAMP INSTALLATION ANGLE, SIDE KNEEL ANGLE, OR ANY COMBINATION THEREOF SHALL NOT EXCEED 2.5°

<p><b>LIFT-U</b> P.O. BOX 398 ESCALON, CA. 95320 209-838-2400</p> <p>A DIVISION OF <b>HOGAN MFG., INC.</b></p>	<p>THIS DOCUMENT IS AND CONTAINS CONFIDENTIAL TRADE SECRET INFORMATION OF THE COMPANY. NO PART OF IT MAY BE REPRODUCED, STORED IN A RETRIEVAL SYSTEM, OR TRANSMITTED IN ANY FORM OR BY ANY MEANS ELECTRONICALLY, PHOTOCOPIED, RECORDED OR OTHERWISE, WITHOUT THE PRIOR WRITTEN PERMISSION OF HOGAN MFG, INC. THIS DOCUMENT IS LOANED FOR THE LIMITED PURPOSES STATED HEREIN ONLY, AND REMAINS THE PROPERTY OF THE COMPANY.</p>
	<p>TITLE <b>RAMP OPERATION/ENVELOPE</b></p> <p>DOCUMENT NO. <b>746-0024</b></p>

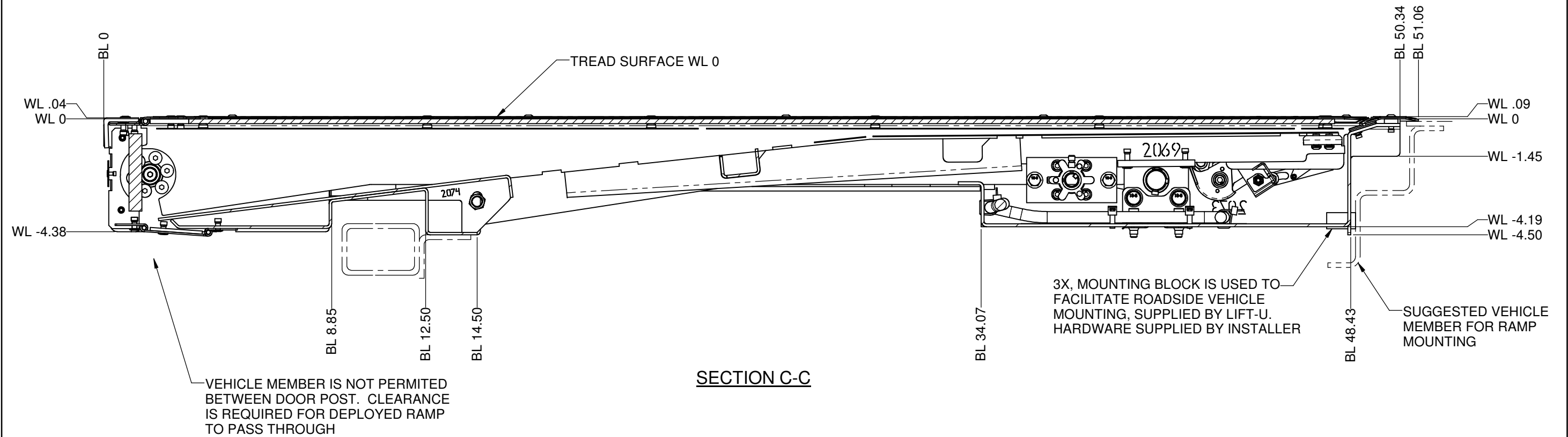

**SECTION C-C**

**RAMP INSTALLATION ANGLE, SIDE KNEEL ANGLE, OR ANY COMBINATION THEREOF SHALL NOT EXCEED 2.5°**

 <b>LIFT-U®</b> P.O. BOX 398 ESCALON, CA. 95320 209-838-2400 A DIVISION OF <b>HOGAN MFG., INC.</b>	THIS DOCUMENT IS AND CONTAINS CONFIDENTIAL TRADE SECRET INFORMATION OF THE COMPANY. NO PART OF IT MAY BE REPRODUCED, STORED IN A RETRIEVAL SYSTEM, OR TRANSMITTED IN ANY FORM OR BY ANY MEANS ELECTRONICALLY, PHOTOCOPYING, RECORDING OR OTHERWISE, WITHOUT THE PRIOR WRITTEN PERMISSION OF HOGAN MFG, INC. THIS DOCUMENT IS LOANED FOR THE LIMITED PURPOSES STATED HEREIN ONLY, AND REMAINS THE PROPERTY OF THE COMPANY.
	<b>TITLE</b> RAMP OPERATION/ENVELOPE <b>DOCUMENT NO.</b> 746-0024 <b>SHEET NO.</b> 2 OF 5 <b>REVISION</b> A

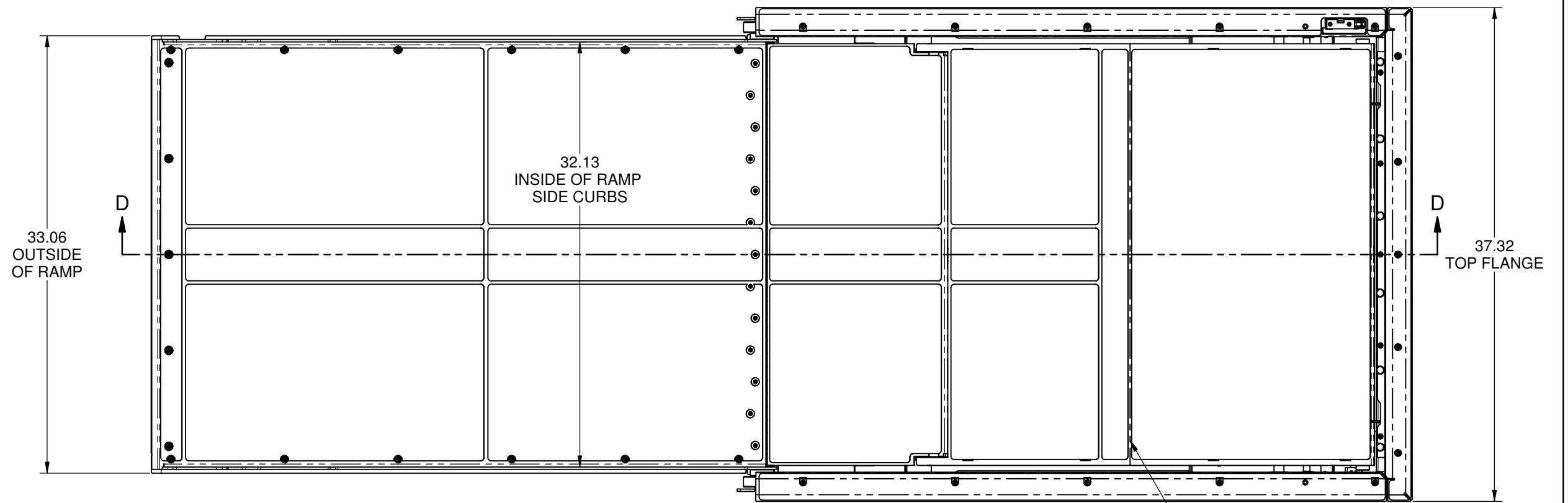

PLAN VIEW  
RAMP DEPLOYED TO GROUND LEVEL

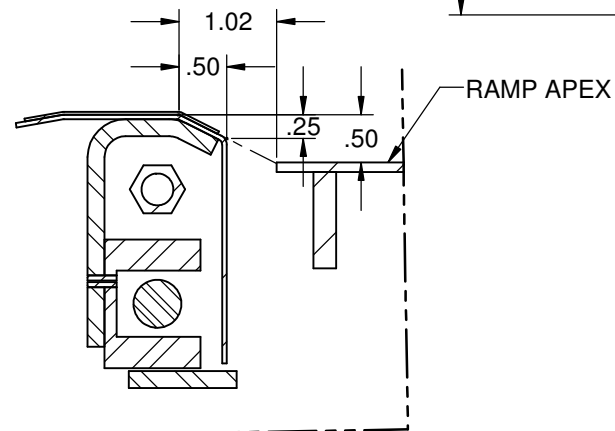

THE DIMENSIONS SHOWN DEFINE THE TRANSITION FROM THE RAMP TO THE VEHICLE FLOOR AT THE APEX. THE TRANSITION DEPICTED ABOVE IS TYPICAL FORWARD AND REAR.

SECTION E-E

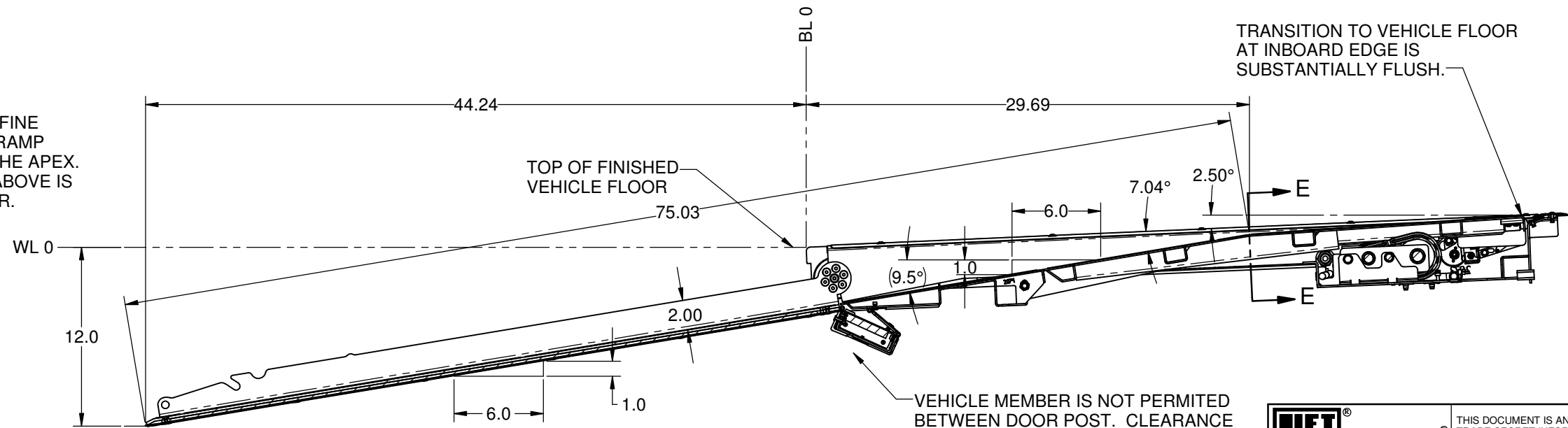

SECTION D-D  
RAMP SHOWN AT MAXIMUM CONDITION

RAMP INSTALLATION ANGLE, SIDE KNEEL ANGLE, OR ANY COMBINATION THEREOF SHALL NOT EXCEED 2.5°

**LIFT-U**  
P.O. BOX 398  
ESCALON, CA. 95320  
209-838-2400  
A DIVISION OF  
**HOGAN MFG., INC.**

THIS DOCUMENT IS AND CONTAINS CONFIDENTIAL TRADE SECRET INFORMATION OF THE COMPANY. NO PART OF IT MAY BE REPRODUCED, STORED IN A RETRIEVAL SYSTEM, OR TRANSMITTED IN ANY FORM OR BY ANY MEANS ELECTRONICALLY, PHOTOCOPIING, RECORDING OR OTHERWISE, WITHOUT THE PRIOR WRITTEN PERMISSION OF HOGAN MFG, INC. THIS DOCUMENT IS LOANED FOR THE LIMITED PURPOSES STATED HEREIN ONLY, AND REMAINS THE PROPERTY OF THE COMPANY.

TITLE	RAMP OPERATION/ENVELOPE		
DOCUMENT NO.	746-0024	SHEET NO.	3 OF 5
		REVISION	A

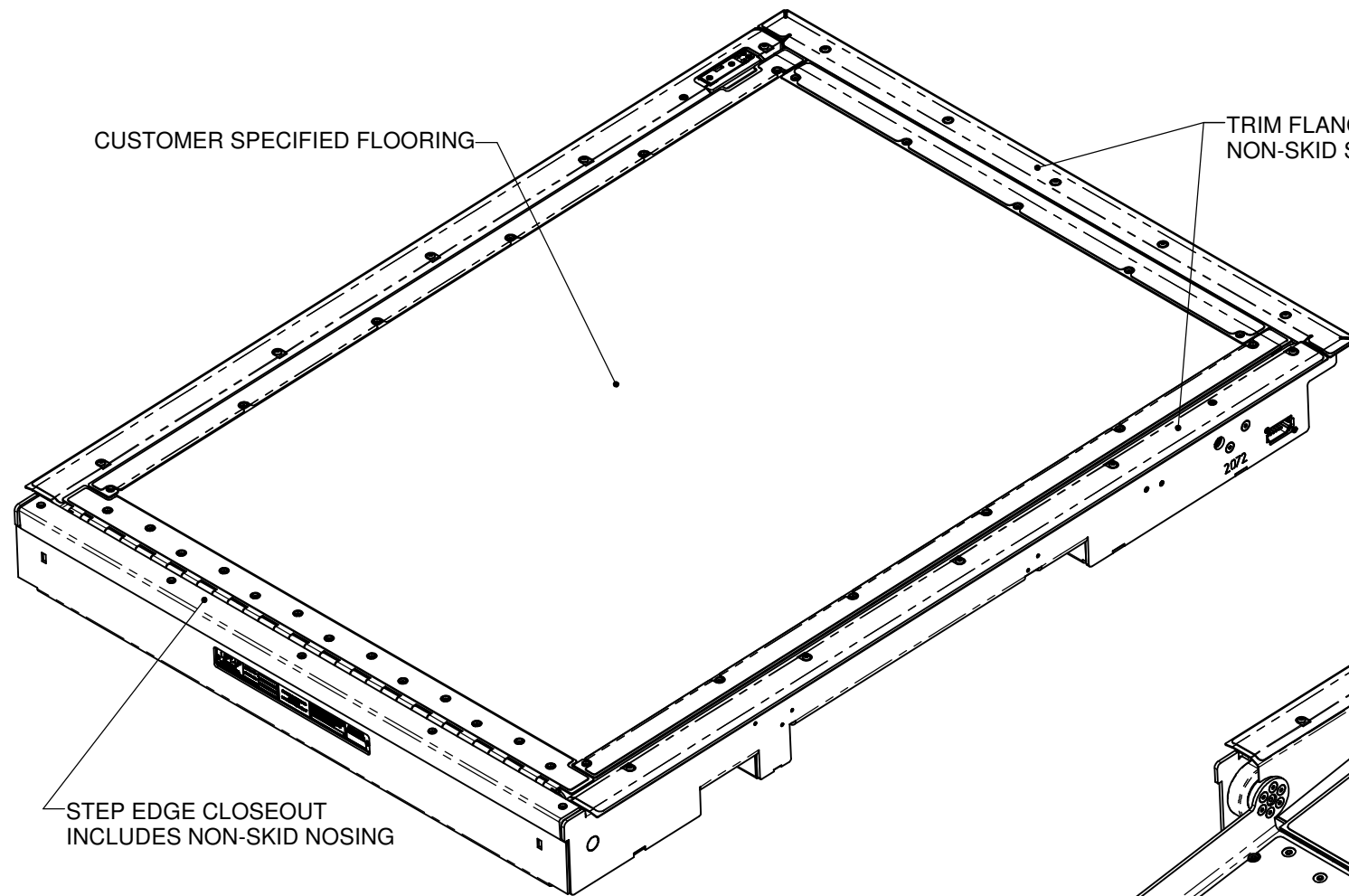

CUSTOMER SPECIFIED FLOORING

TRIM FLANGES INCLUDE  
NON-SKID SURFACE

STEP EDGE CLOSEOUT  
INCLUDES NON-SKID NOSING

ISOMETRIC VIEW  
RAMP STOWED

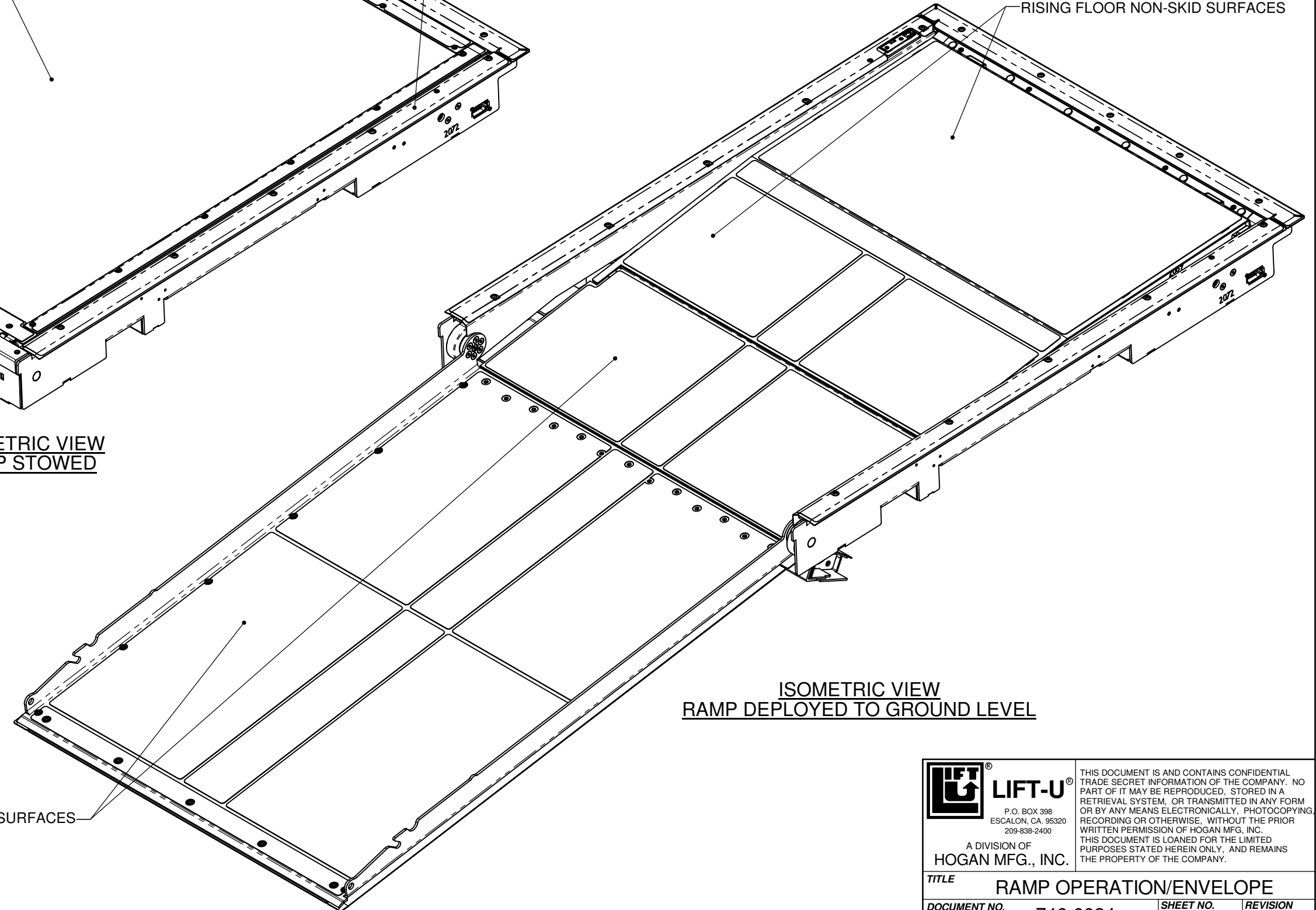

RISING FLOOR NON-SKID SURFACES

RAMP NON-SKID SURFACES

ISOMETRIC VIEW  
RAMP DEPLOYED TO GROUND LEVEL



**LIFT-U**

P.O. BOX 398  
ESCALON, CA. 95320  
209-838-2400

A DIVISION OF  
**HOGAN MFG., INC.**

THIS DOCUMENT IS AND CONTAINS CONFIDENTIAL  
TRADE SECRET INFORMATION OF THE COMPANY. NO  
PART OF IT MAY BE REPRODUCED, STORED IN A  
RETRIEVAL SYSTEM, OR TRANSMITTED IN ANY FORM  
OR BY ANY MEANS ELECTRONICALLY, PHOTOCOPYING,  
RECORDING OR OTHERWISE, WITHOUT THE PRIOR  
WRITTEN PERMISSION OF HOGAN MFG, INC.  
THIS DOCUMENT IS LOANED FOR THE LIMITED  
PURPOSES STATED HEREIN ONLY, AND REMAINS  
THE PROPERTY OF THE COMPANY.

TITLE **RAMP OPERATION/ENVELOPE**

DOCUMENT NO. **746-0024**

SHEET NO.  
**4 OF 5**

REVISION  
**A**

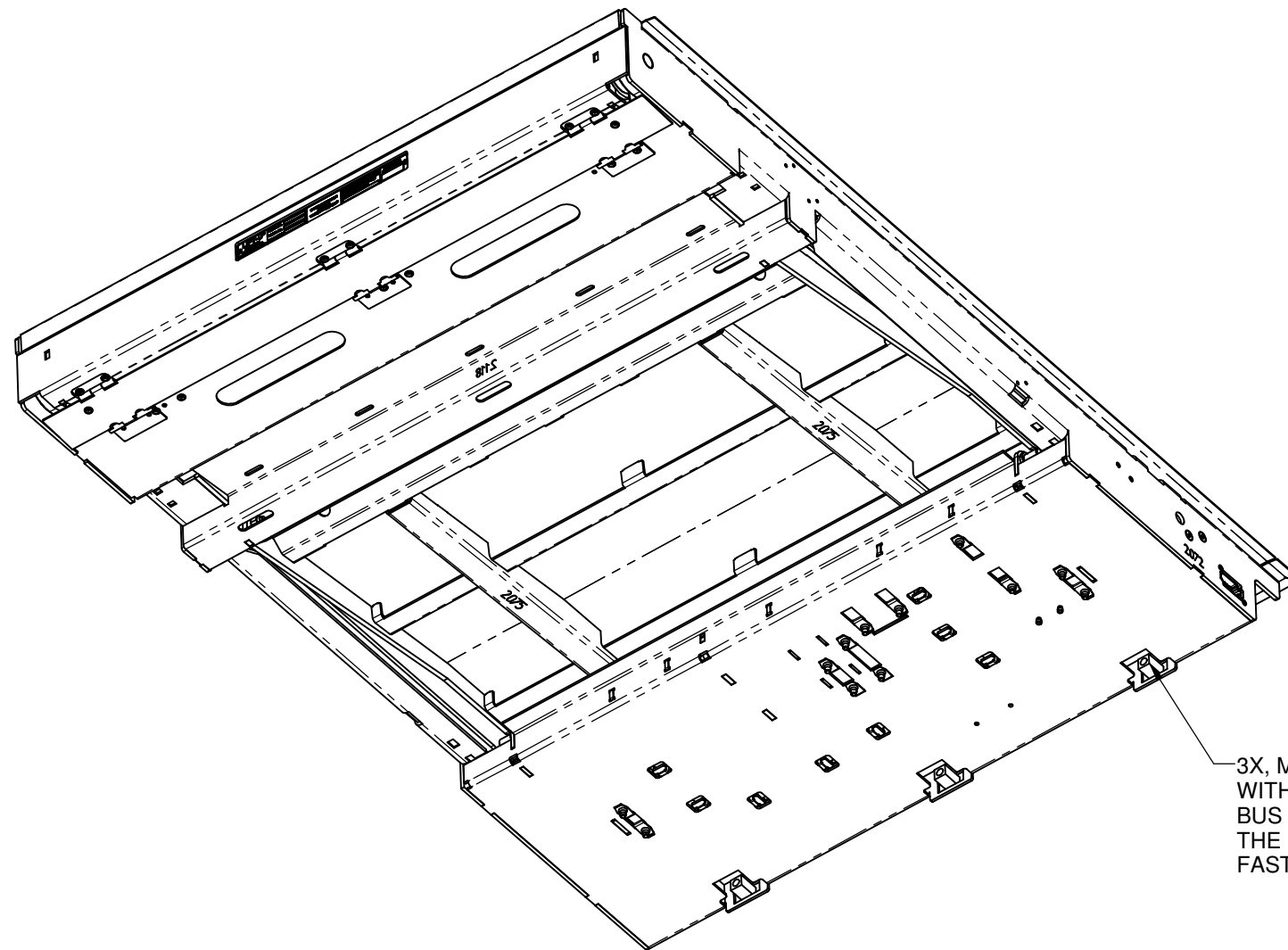

3X, MOUNTING BLOCKS ARE SLIDINGLY ENGAGED WITH THE RAMP FRAME AND BOLTED FAST TO THE BUS CHASSIS BRACKET. THE MOUNTING BLOCKS ARE SUPPLIED BY LIFT-U. FASTENING HARDWARE SUPPLIED BY INSTALLER.

ISOMETRIC VIEW FROM BELOW  
RAMP STOWED



**LIFT-U**<sup>®</sup>

P.O. BOX 398  
ESCALON, CA. 95320  
209-838-2400

A DIVISION OF  
**HOGAN MFG., INC.**

THIS DOCUMENT IS AND CONTAINS CONFIDENTIAL TRADE SECRET INFORMATION OF THE COMPANY. NO PART OF IT MAY BE REPRODUCED, STORED IN A RETRIEVAL SYSTEM, OR TRANSMITTED IN ANY FORM OR BY ANY MEANS ELECTRONICALLY, PHOTOCOPYING, RECORDING OR OTHERWISE, WITHOUT THE PRIOR WRITTEN PERMISSION OF HOGAN MFG, INC. THIS DOCUMENT IS LOANED FOR THE LIMITED PURPOSES STATED HEREIN ONLY, AND REMAINS THE PROPERTY OF THE COMPANY.

TITLE		RAMP OPERATION/ENVELOPE	
DOCUMENT NO.	746-0024	SHEET NO.	5 OF 5
			REVISION A