



LIFT APPLICATION GUIDELINES

ACCESSTAIR – MODEL VMH-08



TABLE OF CONTENTS

GENERAL INFORMATION	3
PURPOSE	3
PRODUCT OVERVIEW	3
SUITABLE LIFT APPLICATIONS	3
APPLICATION GUIDELINES	4
REGULATORY REQUIREMENTS	4
DESIGN PLANNING	5
ACCESSTAIR MODEL VMH SPECIFICATIONS	7
COMPONENTS SUPPLIED BY LIFT-U®	7
RESPONSIBILITY OF OTHERS.....	8
SCOPE OF WORK BY OTHERS.....	8
REGULATORY COMPLIANCE BY OTHERS	8



GENERAL INFORMATION

PURPOSE

LIFT-U® has prepared this document for the purpose of providing building owners and owner representatives such as architects, contractors, and installers with information specific to design planning, special provisions, installation considerations, and regulatory compliance responsibility relevant to the LIFT-U® AccesStair Model VMH Vertical Platform Lift, hereinafter referred to as the VMH.

The information presented in this document is fairly generic for VMH lift applications and not intended to address every detail or special conditions that may be encountered on a project.

PRODUCT OVERVIEW

By way of introduction, the VMH lift model is not a conventional vertical platform lift, but rather a convertible stairway / wheelchair lift. The design is unique, wherein two level change systems are combined into one unit. First, the VMH serves as a stairway between a lower landing and an upper landing. Secondly, the VMH provides accessibility to mobility-impaired persons by retracting the stairs and revealing a vertical platform lift. The unit is electronically controlled and simple to operate.

SUITABLE LIFT APPLICATIONS

VMH units are available to accommodate a vertical rise from 17.50 inches to 50.75 inches in height. Facilities such as schools, museums, performing arts centers, churches, and municipal and public buildings are ideal applications for the convertible stairway / wheelchair lift. The space required for the VMH is typically no greater than the space consumed by traditional stairs. For specific lift envelope dimensions, refer to the Lift Configuration drawing created by LIFT-U® for each VMH project. For general concept information, generic 2, 3, 4, 5 & 6-step VMH Lift Configuration drawings are included (see drawings 910-0080 through 910-0084 respectively).



APPLICATION GUIDELINES

REGULATORY REQUIREMENTS

Vertical Platform Lift design, construction, installation, operation, inspection, testing, maintenance, and repair is specified in Standards developed and published by The American Society of Mechanical Engineers (ASME), entitled ASME A18.1 Safety Standard For Platform Lifts And Stairway Chairlifts. The ASME Standard is intended to serve as the basis for state, municipal, and other jurisdictional authorities in drafting regulations governing Vertical Platform Lifts. With respect to A18.1 effectivity in each jurisdiction, the edition date in effect established by the local jurisdiction may vary; therefore, the local regulations from the authority having jurisdiction (AHJ) must be reviewed prior to each lift installation.

For ASME A18.1 references cited in this document, the latest 2014 edition is used.

Regarding ASME A18.1-2014, Section 2 categories, the AccesStair corresponds most appropriately with “Runway Enclosure Not Provided”, reference para. 2.1.3. However, should the local jurisdiction recognize an older ASME edition, a variance may be required to permit the VMH installation. Should that be the case, LIFT-U® will, on behalf of the building owner, facilitate expediting the variance application.

The basis for a variance request is expressly permitted by A18.1 para. 1.2, which states:

“The purpose of this Standard is to provide for the safety of life and limb, and to promote the public welfare.

The provisions of this Standard are not intended to prevent the use of systems, methods, or devices of equivalent or superior quality, strength, fire resistance, effectiveness, durability, and safety to those prescribed by this Standard provided that there is technical documentation to demonstrate the equivalency of the system, method, or device.

The specific requirements of this Standard shall be permitted to be modified by the authority having jurisdiction based upon technical documentation or physical performance verification to allow alternative arrangements that will assure safety equivalent to that which would be provided by conformance to the corresponding requirements of this Standard.”

For A18.1 regulations applicable to the other trades involved with the lift installation, refer to the section entitled, Regulatory Compliance by Others, on page 8 of this document.



DESIGN PLANNING

There are several elements to consider when planning an AccesStair (VMH) lift application. The following recommendations and alternatives are offered to facilitate a diversity of site conditions and customer preferences. LIFT-U® must be notified of customer-selected options prior to lift manufacturing.

1. VMH upper landing interface options:
 - a. VMH landing may abut the facility landing or stage.
 - b. VMH landing may be cut into the facility landing or stage.
2. The VMH footprint measures 59 inches wide, whereas the footprint length is contingent upon the vertical rise. Refer to included generic lift configuration drawings (910-0080 through 910-0084) for VMH footprint length.
3. Should the intended location of the VMH lift be in a hallway, the hall width must be no less than 60 inches, and the walls adjacent the lift sidewalls must be plumb within ¼ inch.
4. For applications wherein the VMH upper landing is cut into the facility landing or stage, allow for ½" installation clearance on each of the landing's three sides.
5. To be compliant with ADAAG, space at the lower and upper landings must facilitate a wheelchair turning diameter space of 60 inches. Refer to included generic lift configuration drawings (910-0080 through 910-0084).
6. VMH upper landing floor covering options:
 - a. Standard black vinyl.
 - b. Customer may furnish and install preferred wood, laminate, or vinyl floor covering. Allowable floor covering thickness is 5/8" maximum.
7. Operator control panel mounting options at lower and upper landings:
 - a. Lower landing control panel is located on the front of the VMH unit and may be mounted on either the right or left side.
 - b. Upper landing control panel shall be located remote from the VMH unit. The selected location shall enable the operator to have an unobstructed view of lift operation:
 - i) Wall mounted - Flush. This configuration is standard unless requested otherwise – see drawing 910-0059 included at the back of this document. The appropriate enclosure will be provided for mounting "in-the-wall".
 - ii) Wall mounted - Surface. This alternative is available upon request. The appropriate enclosure for this option will be provided for mounting "on-the-wall".
 - iii) Independent pedestal / column. This option is for installations where adjacent walls are not available.



8. Historically, the lift main power disconnect was mounted remote on a nearby wall. That is no longer necessary with the VMH lift. A lockable and fused main power line disconnect is incorporated on the unit itself at the upper landing. The main power disconnect is readily accessible to qualified persons and within sight of the motor controller (NFPA 70, para. 620-51). Refer to drawing 910-0059 included at the back of this document for source power interface / j-box location.
9. The VMH lift includes an audible alarm, which complies with the emergency signaling device requirements specified in ASME A18.1-2014, para. 2.11.1. However, in some jurisdictions the AHJ may prefer the emergency signaling device to be of the two-way communication type (i.e., telephone or intercom) noted as an alternative in para. 2.11.2. As an add-on option, LIFT-U® can provide a two-way speaker-phone installed on the VMH unit. Interface with the building intercom or phone system is the responsibility of the building owner or owner's designated representative.
10. The VMH is available in three textured powder coated finish colors:
 - a. Tan
 - b. Brown
 - c. Black

To further facilitate the architectural design process, design files such as 2D CAD drawings and 3D images, contact LIFT-U® at 209-838-2400 or e-mail at markramos@hoganmfg.com or donbirdsall@hoganmfg.com.



ACCESSTAIR MODEL VMH SPECIFICATIONS

1. The VMH lift complies with ASME A18.1-2014 and ADAAG.
2. Platform dimensions: 36 inches wide by 55 inches long.
3. Lift capacity (maximum operating load): 750 lbs.
4. Speed: 10 ft./min. maximum.
5. Drive: 2 ACME screw jacks.
6. Vertical travel: 18 inches minimum – 50 inches maximum.
7. Finish: all surfaces are powder coated with a textured finish.
8. Power source requirements: 208/230 VAC, 20 amp, 3 wire, single-phase service.
9. Battery back-up: Uninterruptible power supply (UPS) is included.
10. Manual lowering device: included.
11. Shipping weight: approximately 4000 lbs.

COMPONENTS SUPPLIED BY LIFT-U®

The VMH lift package as delivered includes the following:

1. Lift Assembly.
2. Operator Control Panel for upper control station.
3. Wall Mounted Enclosure for upper control station.
4. Labels (operating instructions and warnings).
5. Anchor Bolts.
6. Touch-up paint.
7. Maintenance Manual
8. Training
9. Warranty



RESPONSIBILITY OF OTHERS

SCOPE OF WORK BY OTHERS

The design, materials, construction, and installation of the following items are the responsibility of others.

1. Lift support structure/foundation. Note: this equipment may require reinforcement of the foundation / floor in order to bear the loads associated with the unit. Refer to drawing 910-0058 included at the back of this document for anchor bolt and load data. Evaluation of these loads and their effect on the structure, as well as any reinforcement required, is by others.
2. Site preparations, including main electrical power connection to lift power input, and associated conduit. Refer to drawing 910-0059 included at the back of this document for source power interface / j-box location.
3. Prior to installation, placement of lift must be defined.
4. Building elements adjacent to the lift, including but not limited to structural framing of landings and walls, and wall finishes.
5. Installation of wall mounted enclosure (supplied by LIFT-U®) for upper control station. Refer to drawing 910-0059 included at the back of this document. Associated conduit for control cables is by others, if required.
6. Installation of applicable operation and warning labels (supplied by LIFT-U®).
7. Illumination of lift area.
8. If required, interface of two-way speaker-phone (supplied by LIFT-U®) with the building intercom or phone system.

REGULATORY COMPLIANCE BY OTHERS

The ASME A18.1 specifies requirements for the design, construction, installation, operation, inspection, testing, maintenance, and repair for Vertical Platform Lifts.

With respect to the VMH installation, while LIFT-U® is required to certify that the lift complies with the A18.1 Standard and any variance decisions granted by the AHJ, there are certain requirements associated with elements necessary for the installation of a complete lift system that are not provided by LIFT-U®, and therefore require the cooperation of other trades contracted by the building owner. Subsequently, these other trades are responsible for compliance with the A18.1 requirements related to their respective work. These elements are outlined in the Scope of Work by Others noted above.

LIFT-U® hereby advises the building owner, or owner's designated representative, of the owner's responsibility to communicate the applicable A18.1 requirements to the appropriate trades. To facilitate this effort, LIFT-U® has summarized below the A18.1 requirements that other trades involved with the lift installation must comply with - *refer to the A18.1 Standard for complete text.*



2.1.5 Pipes in Runway Vicinity

- No piping is permitted in the runway [*lift footprint*].

2.1.8 Structural Support

- The structure on which the equipment is installed shall be capable of safely supporting the loads imposed. LIFT-U® provides the building owner, or owner's representative, with the appropriate load data.

2.1.9 Headroom Clearance

- Headroom clearance throughout the range of travel shall be not less than 79 inches as measured vertically from the platform floor. Refer to the Lift Configuration drawing for lift operational envelope dimensions.

2.6.6 Illumination

- 2.6.6.1** At the threshold of the floor, the minimum illumination shall be not less than 5 ftc (50 lx).
- 2.6.6.2** During operation, the minimum illumination on the floor and controls shall be not less than 5 ftc (50 lx).
- 2.6.6.3** An auxiliary illumination source to provide general illumination of not less than 0.2 ftc (2.2 lx) on the floor and controls shall be provided. The auxiliary system shall be automatically activated when normal illumination power fails and shall be capable of maintaining the above illumination intensity for a period of not less than 4 hr and shall use no fewer than two lamps of approximately equal wattage.

2.10.1 Operator Control Stations

- Controls shall be located between 48 inches maximum and 15 inches minimum above the platform floor or facility floor or ground level. Although the maximum height of 48 inches is specified in ASME A18.1, LIFT-U® recommends consulting local codes for preferred control locations.

2.11 Emergency Signals

- If the platform is installed in an area not visible to personnel at all times, an emergency signaling device such as an alarm, or a means of two-way conversation (telephone or intercom) shall be provided. Further, the signaling device(s) shall automatically transfer to standby or emergency power should the building power supply fail. The VMH lift includes an audible alarm and battery back-up system; however, should the AHJ or customer prefer a speaker-phone for two-way communication, LIFT-U® can provide such a device; but the interface with the building intercom or phone system is the responsibility of the building owner or owner's designated representative.

REVISIONS									
LTR	ECO	APPD	DATE	DESCRIPTION	DFTR	DATE	CHKR	DATE	
A				RELEASED	ARC	4/4/2008	ARC	6/20/2008	
B				ADD INFO. TO ANCHOR CALLOUT	ECW	2/26/2009			

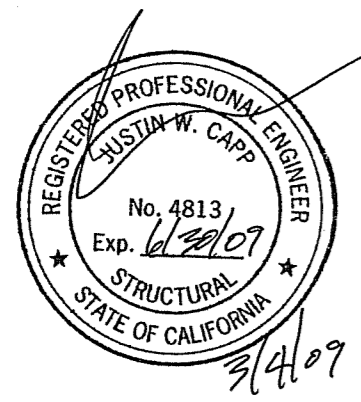
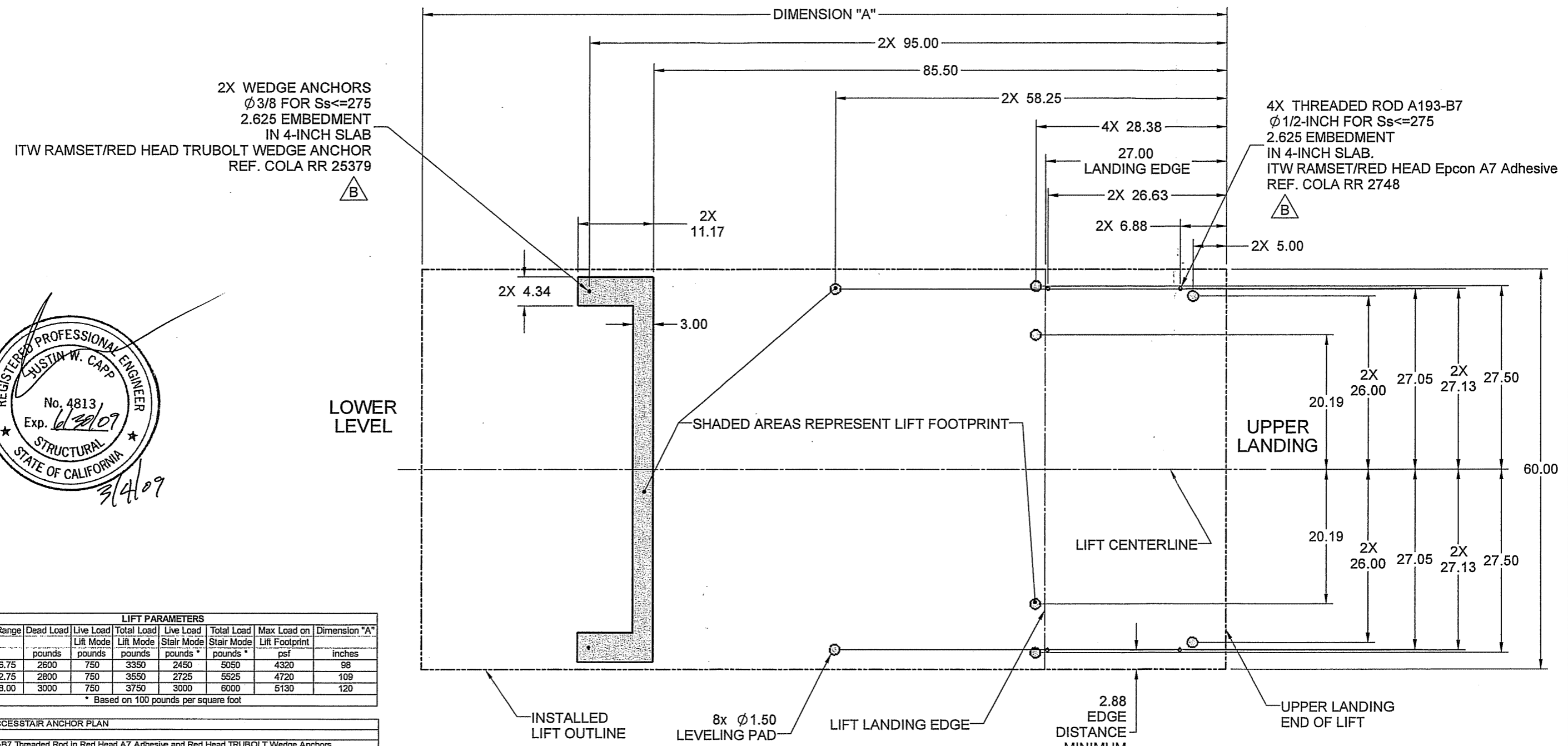

LIFT PARAMETERS							
Lift Height Range	Dead Load	Live Load	Total Load	Live Load	Total Load	Max Load on	Dimension "A"
inches	pounds	pounds	pounds	pounds *	pounds *	psf	inches
24.00 to 36.75	2600	750	3350	2450	5050	4320	98
36.75 to 42.75	2800	750	3550	2725	5525	4720	109
42.75 to 48.00	3000	750	3750	3000	6000	5130	120

* Based on 100 pounds per square foot

VM-2008 ACCESSTAIR ANCHOR PLAN									
6/20/2008									
ASTM A193-B7 Threaded Rod in Red Head A7 Adhesive and Red Head TRUBOLT Wedge Anchors									
Occupancy	Site Class	Ss	Concrete	Level Above	Anchor	Embedment	Allowable	Pull	
Category		%g	Strength	Ground	Size	in	Service Load	Test	
			psi	ft	in	in	pounds	pounds	
III	D	275	2000	0	1/2	2.625	1558	3116	

ITW RAMSET/RED HEAD Epcon A7 Adhesive COLA RR 25379				
Anchor Dia	Embed	Tension	Shear	
in	in	2000psi	2000psi	
		pounds	pounds	
	0.000	0	0	
	2.625	1558	1170	
1/2	4.500	2670	2005	

ITW RAMSET/RED HEAD TRUBOLT WEDGE ANCHOR COLA RR 2748 without special inspection				
Anchor Dia	Embed	Tension	Shear	
in	in	2000psi	2000psi	
		pounds	pounds	
	1.500	210	580	
	2.625	379	895	
3/8	3.000	435	1000	

INSTALLATION TORQUE 25 LBF-FT

ANCHOR PLAN

UNLESS OTHERWISE SPECIFIED:

- INTERPRET DRAWING PER ANSI Y14.5-1982.
- DIMENSIONS ARE IN INCHES.
- FINISH ALL PROCESSED SURFACES TO 125 RMS MAX.
- DIMENSIONS APPLY TO FINISHED PART, BEFORE PAINTING.
- DEBURR ALL SURFACES AND BREAK ALL EDGES .015 x 45°.
- TOLERANCES (+ OR -):

DECIMAL: .XX = .03, .XXX = .010, .XXXX = .0005
 FRACTION: 1/16
 ANGLE: 1/2 DEGREE

COATING / FINISH
 DESC: NONE
 SPEC: NONE

FIRST USE REFERENCE:
 VMH 2008

SCALE: 1:8 **WEIGHT:** (LBS.)

LIFT LIFT-U
 P.O. BOX 388
 ESCALON, CA. 95320
 209-838-2400
 A DIVISION OF
HOGAN MFG., INC.
 THIS DOCUMENT IS AND CONTAINS CONFIDENTIAL TRADE SECRET INFORMATION OF THE COMPANY. NO PART OF IT MAY BE REPRODUCED, STORED IN A RETRIEVAL SYSTEM, OR TRANSMITTED IN ANY FORM OR BY ANY MEANS ELECTRONICALLY, PHOTOCOPYING, RECORDING OR OTHERWISE, WITHOUT THE PRIOR WRITTEN PERMISSION OF HOGAN MFG, INC. THIS DOCUMENT IS LOANED FOR THE LIMITED PURPOSES STATED HEREIN ONLY, AND REMAINS THE PROPERTY OF THE COMPANY.

TITLE
 ACCESSTAIR ANCHOR PLAN

DOCUMENT NO. 910-0058 **SHEET NO.** 1 OF 1 **REVISION** B

REVISIONS									
LTR	ECO	APPD	DATE	DESCRIPTION	DFTR	DATE	CHKR	DATE	
A				RELEASED	BSA	6/10/2008			
B				UPDATED J-BOX LOCATION CHART	BRB	9/19/2011			
C				ADDED "SIZE" & "24 MIN" DIMENSIONS	BSA	4/18/2012			

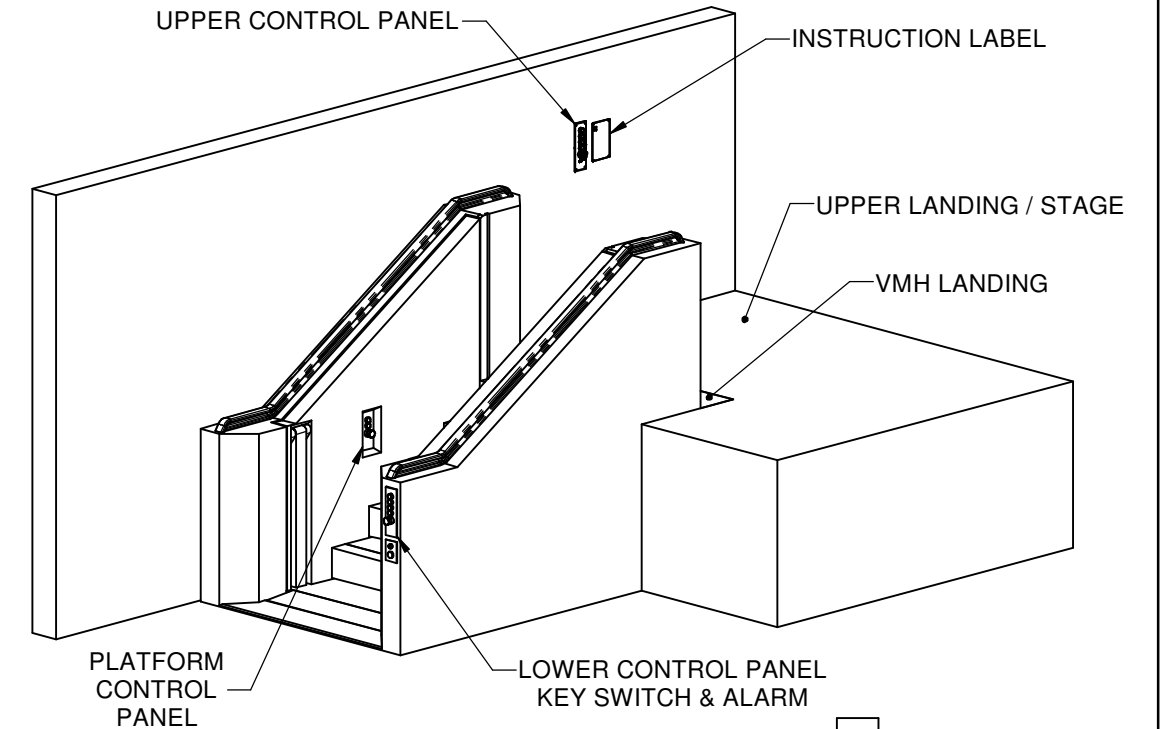
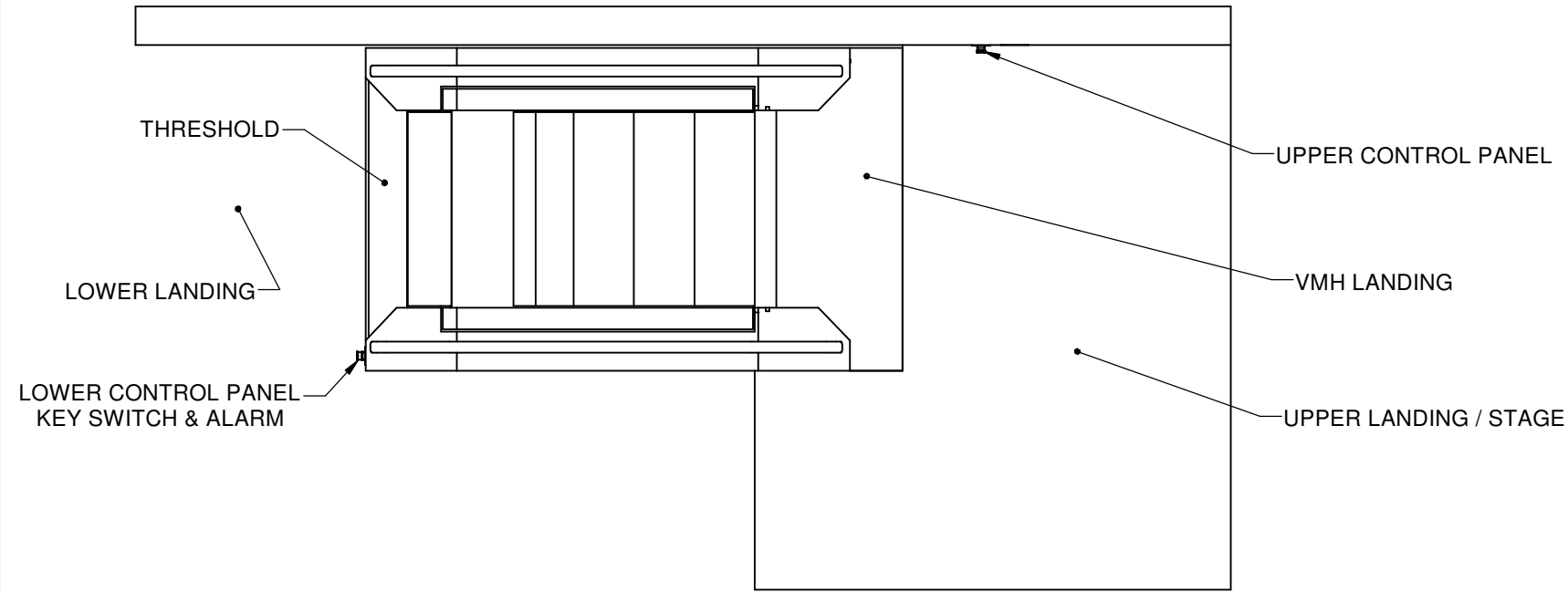

ENCLOSURE AND CONTROL PANEL (SUPPLIED BY LIFT-U)
ENCLOSURE AND CONDUIT INSTALLED BY CONTRACTOR.
OPTIONAL SURFACE MOUNTED ENCLOSURE AVAILABLE

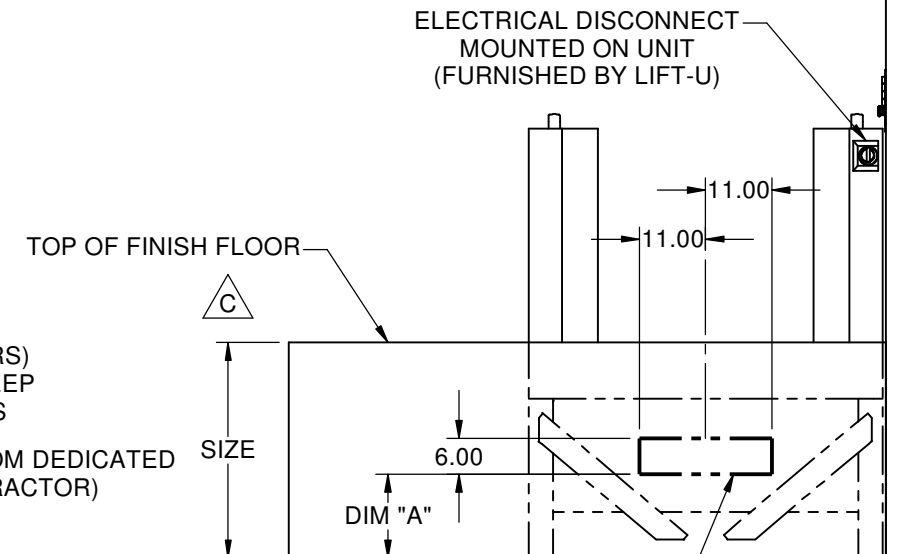
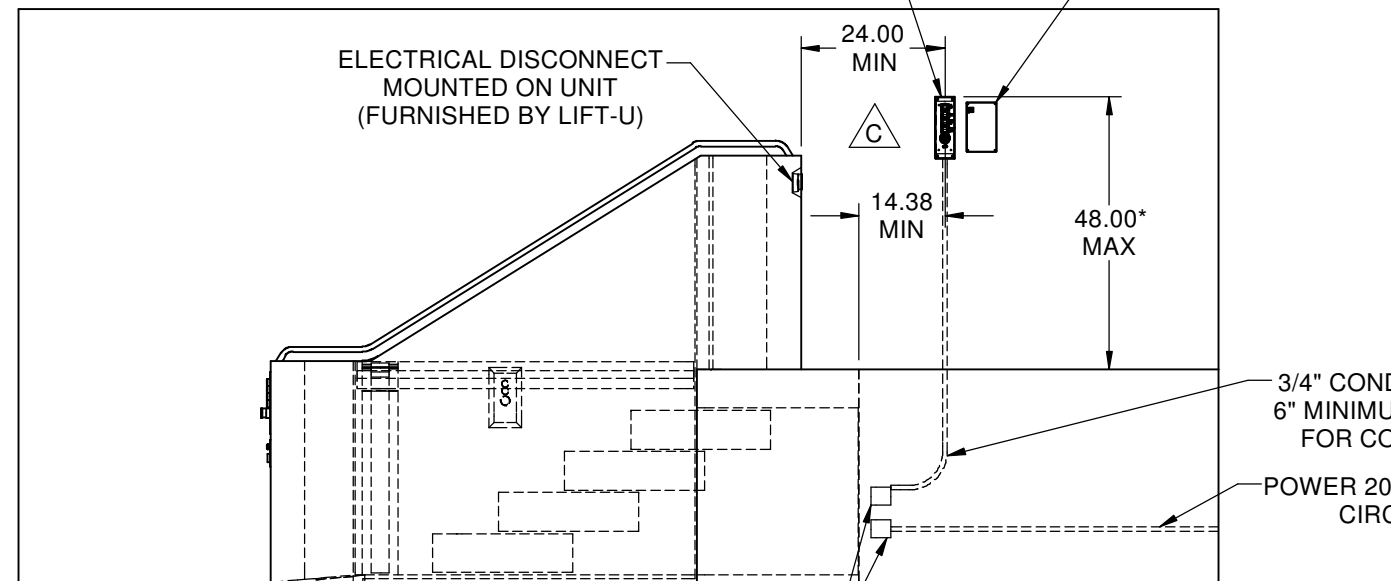

J-BOXES & CONDUITS INSTALLED BY CONTRACTOR (BY OTHERS) FOR AC AND DC LINES, ACCESSIBLE TO LIFT CONNECTIONS BELOW LANDING.

* = CONSULT WITH LOCAL CODES

ALLOWABLE ZONE FOR J-BOX LOCATION AT BACK OF LANDING. J-BOXES (BY OTHERS) FOR AC AND DC LINES, ACCESSIBLE TO LIFT CONNECTIONS BELOW LANDING.

SIZE	DIM "A"
18.00" - 23.99"	6"
24.00" - 29.99"	14"
30.00" - 35.99"	18"
36.00" - 41.99"	24"
42.00" - 47.99"	25"

NOTE:
THIS DRAWING IS GENERIC AND PROVIDED FOR INFORMATION ONLY.
REFER TO LIFT CONFIGURATION FOR SPECIFIC SITE CONDITIONS.

UNLESS OTHERWISE SPECIFIED:

- INTERPRET DRAWING PER ANSI Y14.5-1982.
- DIMENSIONS ARE IN INCHES.
- FINISH ALL PROCESSED SURFACES TO 125 RMS MAX.
- DIMENSIONS APPLY TO FINISHED PART, BEFORE PAINTING.
- DEBURR ALL SURFACES AND BREAK ALL EDGES .015 x 45 °.
- TOLERANCES (+ OR -):

DECIMAL:	FRACTION: 1/16
.XX = .03	
.XXX = .010	ANGLE: 1/2 DEGREE
.XXXX = .0005	

COATING / FINISH

DESC: NONE

SPEC: NONE

FIRST USE REFERENCE:

VMH

SCALE: N/A

WEIGHT: (LBS.) N/A



A DIVISION OF
HOGAN MFG., INC.

TITLE

OPERATOR CONTROLS LAYOUT

DOCUMENT NO.

910-0059

SHEET NO.

1 OF 1

REVISION

C

THIS DOCUMENT IS AND CONTAINS CONFIDENTIAL TRADE SECRET INFORMATION OF THE COMPANY. NO PART OF IT MAY BE REPRODUCED, STORED IN A RETRIEVAL SYSTEM, OR TRANSMITTED IN ANY FORM OR BY ANY MEANS ELECTRONICALLY, PHOTOCOPYING, RECORDING OR OTHERWISE, WITHOUT THE PRIOR WRITTEN PERMISSION OF HOGAN MFG, INC. THIS DOCUMENT IS LOANED FOR THE LIMITED PURPOSES STATED HEREIN ONLY, AND REMAINS THE PROPERTY OF THE COMPANY.

REVISIONS									
LTR	ECO	APPD	DATE	DESCRIPTION	DFTR	DATE	CHKR	DATE	
A				RELEASED	CAL	3/13/2009			
B				ADDED 60" TURN SPACE, NOTES & SHEET 2	BSA	10/18/2011			

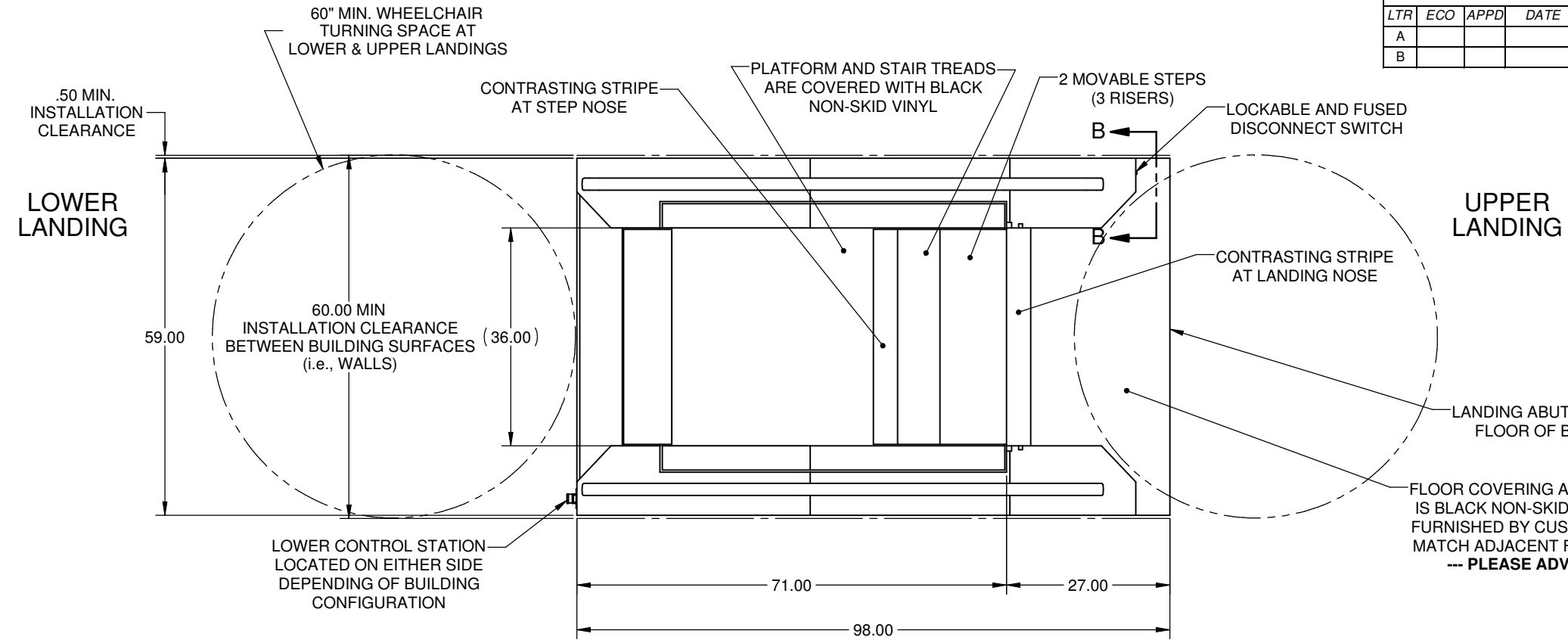

- NOTES:**
1. THIS DRAWING IS SUBJECT TO CHANGE PENDING APPLICABLE STATE AND LOCAL CODES, AND CUSTOMER APPROVAL.
 2. CUSTOMER MUST PROVIDE APPLICABLE STATE AND LOCAL CODES TO LIFT-U PRIOR TO DESIGN.
 3. DRAWING MUST BE SIGNED BY CUSTOMER AND RETURNED TO LIFT-U PRIOR TO PRODUCTION RELEASE. CUSTOMER APPROVAL SIGNIFIES THAT ALL DIMENSIONS ARE CORRECT TO THEIR SPECIFICATIONS.
 4. SEE SHEET 2 OF 3 FOR LIFT SPECIFICATIONS.

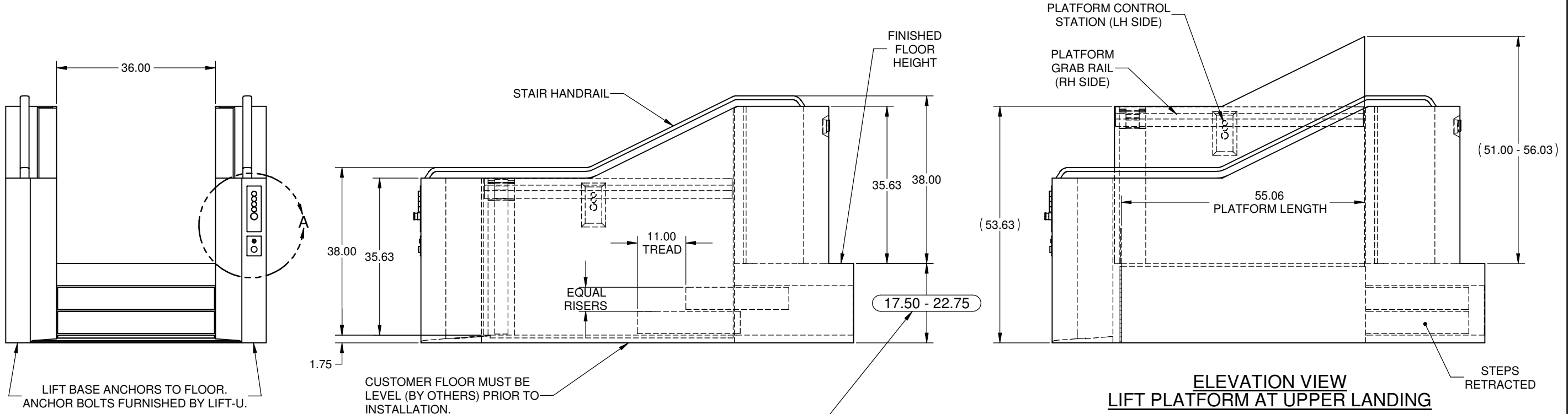

ELEVATION VIEW STEPS CONFIGURATION

ELEVATION VIEW LIFT PLATFORM AT UPPER LANDING

APPROVAL NOTE:
CONTRACTOR MUST VERIFY LANDING HEIGHT PRIOR TO RELEASE FOR FABRICATION. MEASUREMENT TO BE TAKEN FROM BASE FLOOR AT THE LOWER LANDING TO THE FINISH FLOOR AT THE UPPER LANDING.

<p>LIFT-U P.O. BOX 398 ESCALON, CA. 95320 209-838-2400</p> <p>A DIVISION OF HOGAN MFG., INC.</p>	<p>THIS DOCUMENT IS AND CONTAINS CONFIDENTIAL TRADE SECRET INFORMATION OF THE COMPANY. NO PART OF IT MAY BE REPRODUCED, STORED IN A RETRIEVAL SYSTEM, OR TRANSMITTED IN ANY FORM OR BY ANY MEANS ELECTRONICALLY, PHOTOCOPIING, RECORDING OR OTHERWISE, WITHOUT THE PRIOR WRITTEN PERMISSION OF HOGAN MFG, INC. THIS DOCUMENT IS LOANED FOR THE LIMITED PURPOSES STATED HEREIN ONLY, AND REMAINS THE PROPERTY OF THE COMPANY.</p>	
	<p>TITLE LIFT CONFIGURATION, 2-STEP</p>	
<p>DOCUMENT NO. 910-0080</p>	<p>SHEET NO. 1 OF 2</p>	<p>REVISION B</p>

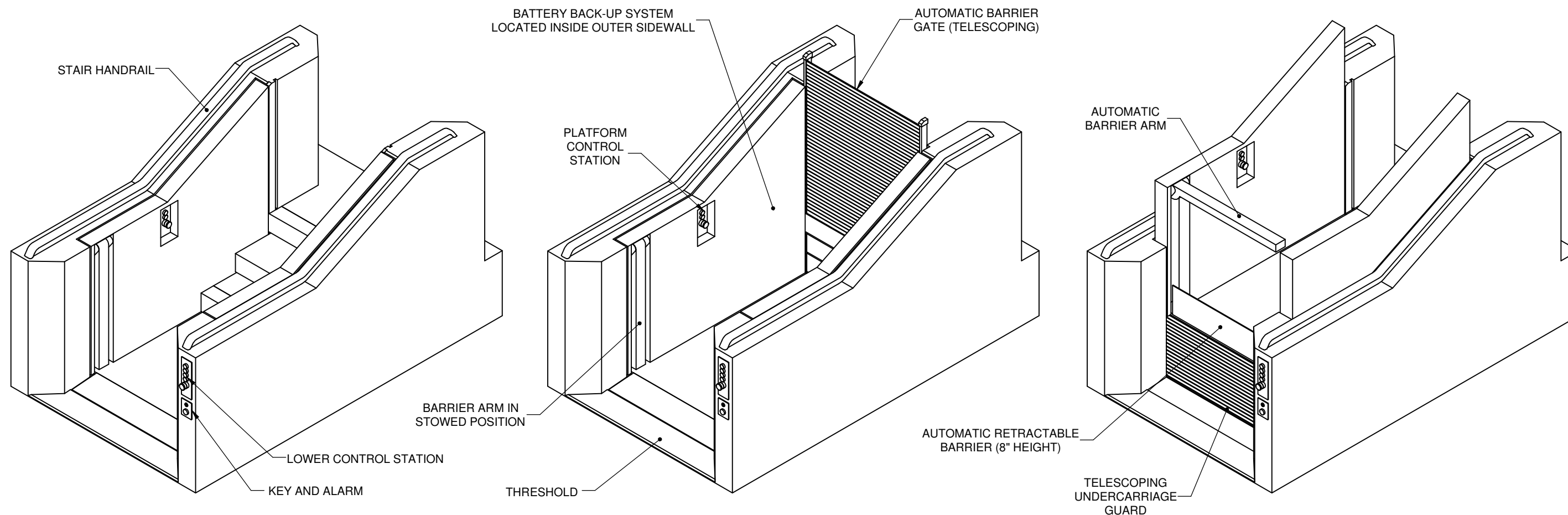

STEPS CONFIGURATION

STEPS RETRACTED
READY FOR PASSENGER INGRESS OR EGRESS

LIFT PLATFORM AT UPPER LANDING
READY FOR PASSENGER INGRESS OR EGRESS

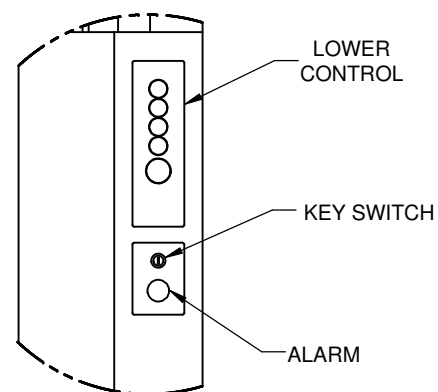

DETAIL A

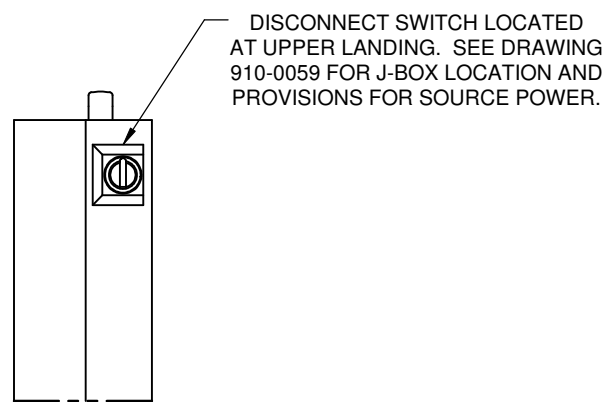

SECTION B-B

VIEW ROTATED FOR CLARITY

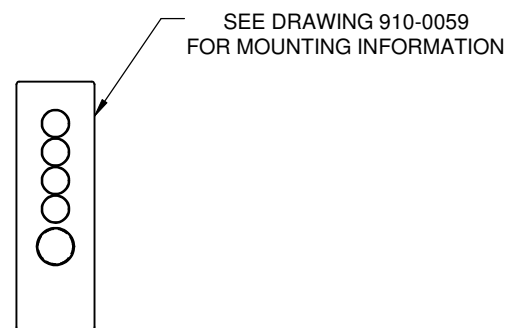

UPPER CONTROLS STATION

REFERENCE ONLY



A DIVISION OF
HOGAN MFG., INC.

THIS DOCUMENT IS AND CONTAINS CONFIDENTIAL TRADE SECRET INFORMATION OF THE COMPANY. NO PART OF IT MAY BE REPRODUCED, STORED IN A RETRIEVAL SYSTEM, OR TRANSMITTED IN ANY FORM OR BY ANY MEANS ELECTRONICALLY, PHOTOCOPYING, RECORDING OR OTHERWISE, WITHOUT THE PRIOR WRITTEN PERMISSION OF HOGAN MFG., INC. THIS DOCUMENT IS LOANED FOR THE LIMITED PURPOSES STATED HEREIN ONLY, AND REMAINS THE PROPERTY OF THE COMPANY.

TITLE **LIFT CONFIGURATION, 2-STEP**

DOCUMENT NO. **910-0080**

SHEET NO. **2 OF 2**

REVISION **B**

REVISIONS									
LTR	ECO	APPD	DATE	DESCRIPTION	DFTR	DATE	CHKR	DATE	
A				RELEASED	CAL	3/13/2009			
B				ADDED 60" TURN SPACE, NOTES & SHEET 2	BSA	10/18/2011			

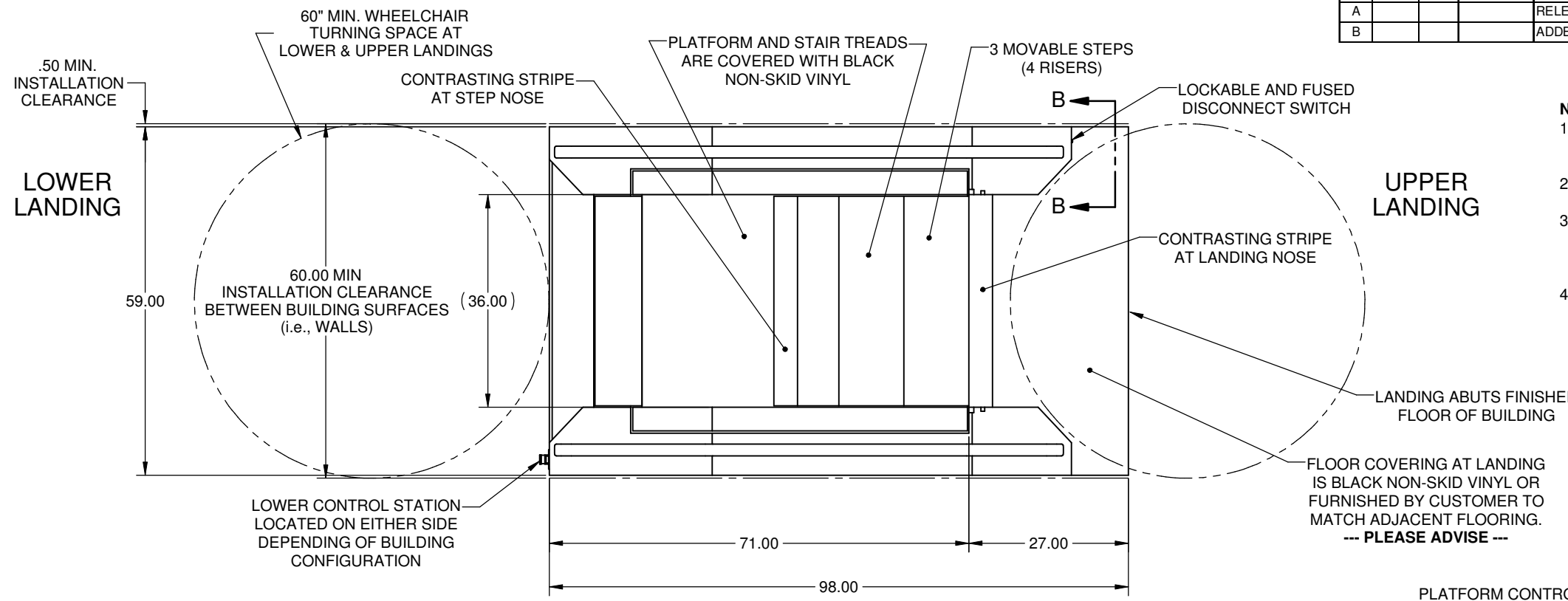

- NOTES:**
1. THIS DRAWING IS SUBJECT TO CHANGE PENDING APPLICABLE STATE AND LOCAL CODES, AND CUSTOMER APPROVAL.
 2. CUSTOMER MUST PROVIDE APPLICABLE STATE AND LOCAL CODES TO LIFT-U PRIOR TO DESIGN.
 3. DRAWING MUST BE SIGNED BY CUSTOMER AND RETURNED TO LIFT-U PRIOR TO PRODUCTION RELEASE. CUSTOMER APPROVAL SIGNIFIES THAT ALL DIMENSIONS ARE CORRECT TO THEIR SPECIFICATIONS.
 4. SEE SHEET 2 OF 3 FOR LIFT SPECIFICATIONS.

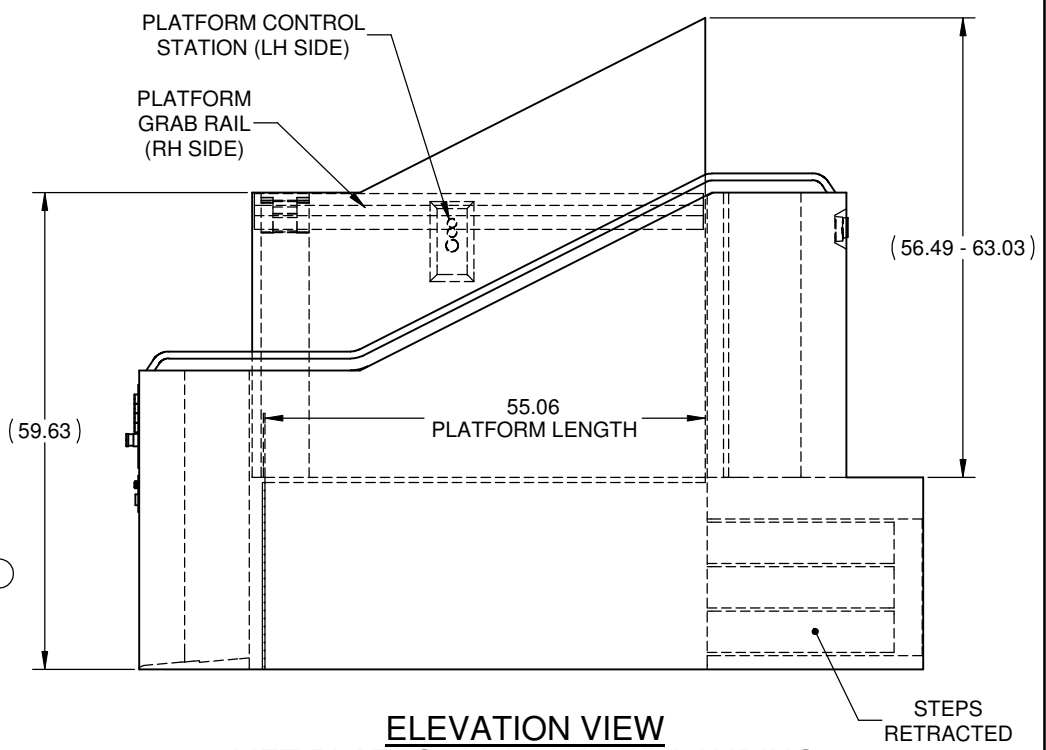
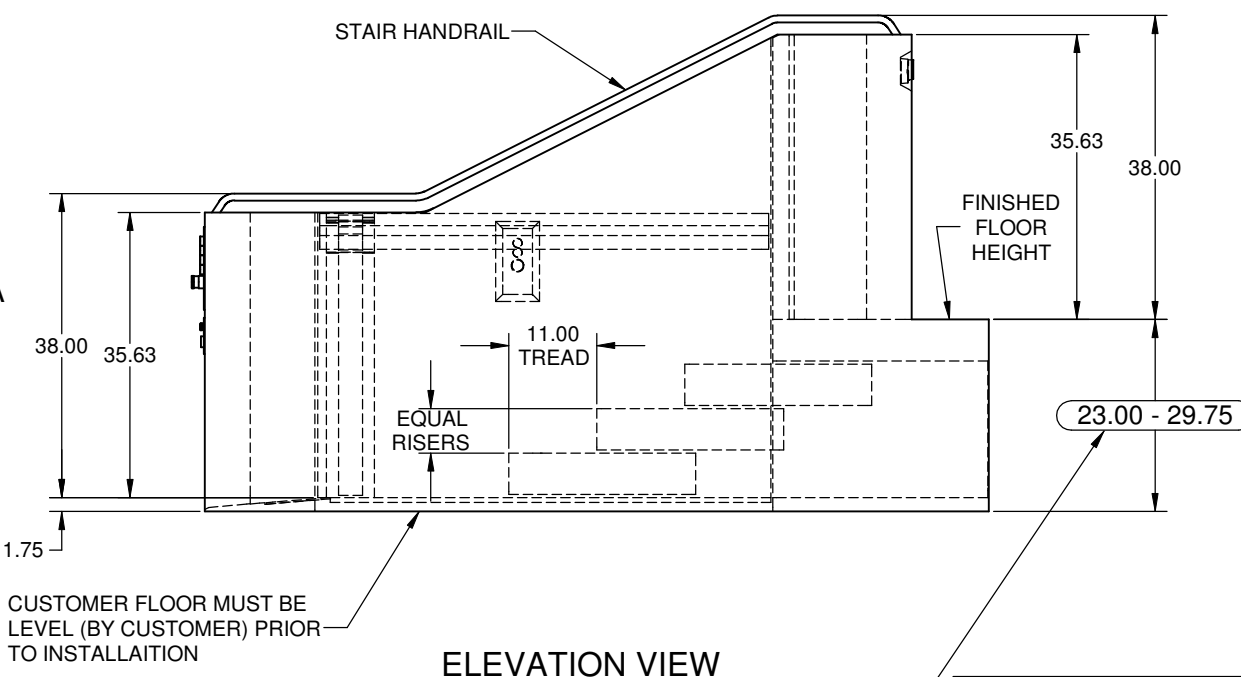
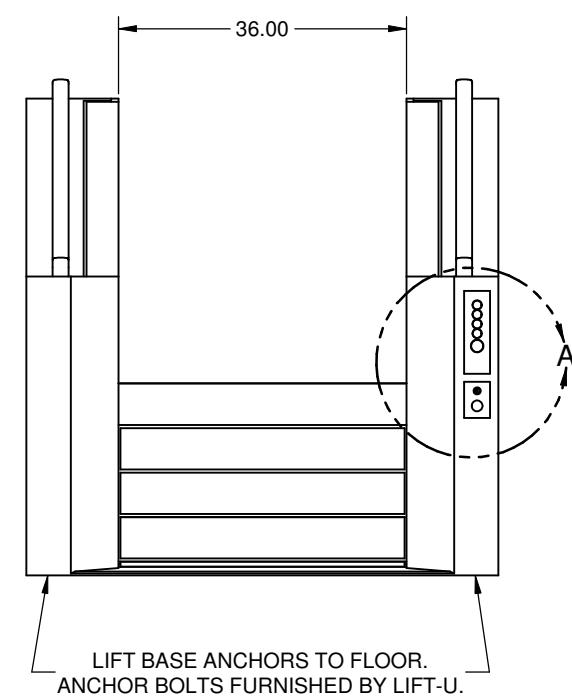

APPROVAL NOTE:
CONTRACTOR MUST VERIFY LANDING HEIGHT PRIOR TO RELEASE FOR FABRICATION. MEASUREMENT TO BE TAKEN FROM BASE FLOOR AT THE LOWER LANDING TO THE FINISH FLOOR AT THE UPPER LANDING.

LIFT-U
 P.O. BOX 398
 ESCALON, CA. 95320
 209-838-2400

A DIVISION OF
HOGAN MFG., INC.

THIS DOCUMENT IS AND CONTAINS CONFIDENTIAL TRADE SECRET INFORMATION OF THE COMPANY. NO PART OF IT MAY BE REPRODUCED, STORED IN A RETRIEVAL SYSTEM, OR TRANSMITTED IN ANY FORM OR BY ANY MEANS ELECTRONICALLY, PHOTOCOPIING, RECORDING OR OTHERWISE, WITHOUT THE PRIOR WRITTEN PERMISSION OF HOGAN MFG, INC. THIS DOCUMENT IS LOANED FOR THE LIMITED PURPOSES STATED HEREIN ONLY, AND REMAINS THE PROPERTY OF THE COMPANY.

TITLE LIFT CONFIGURATION, 3-STEP

DOCUMENT NO. 910-0081 **SHEET NO.** 1 OF 2 **REVISION** B

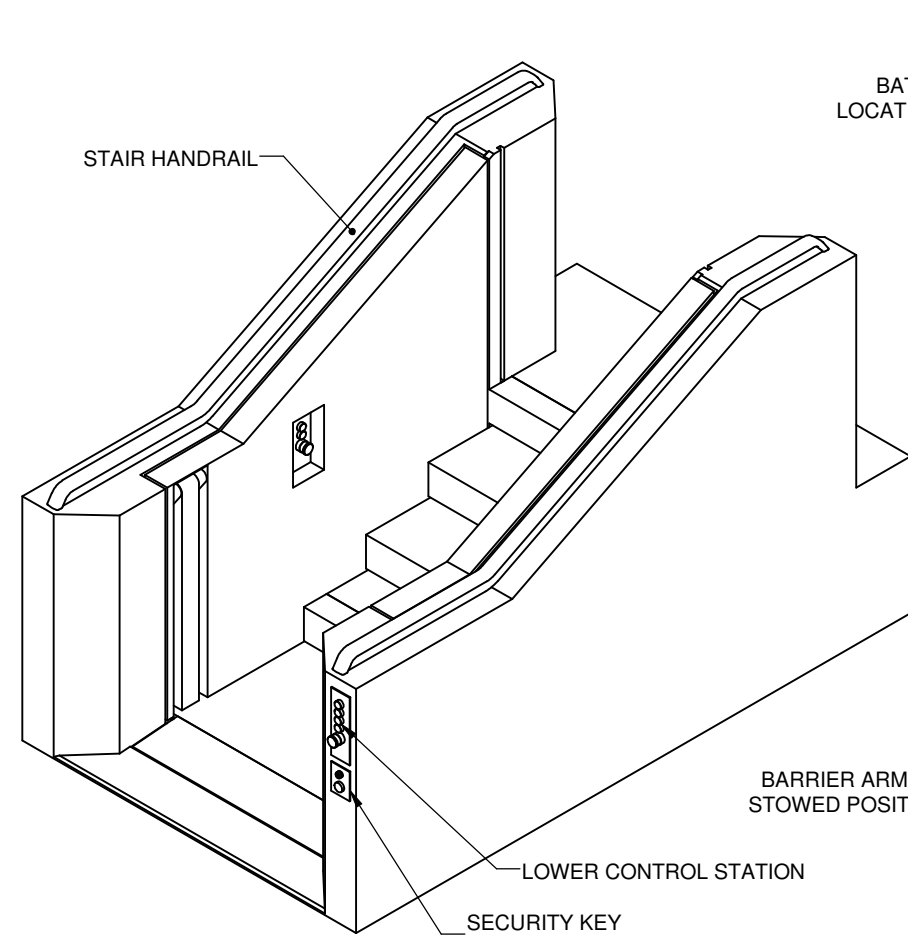

STEPS CONFIGURATION

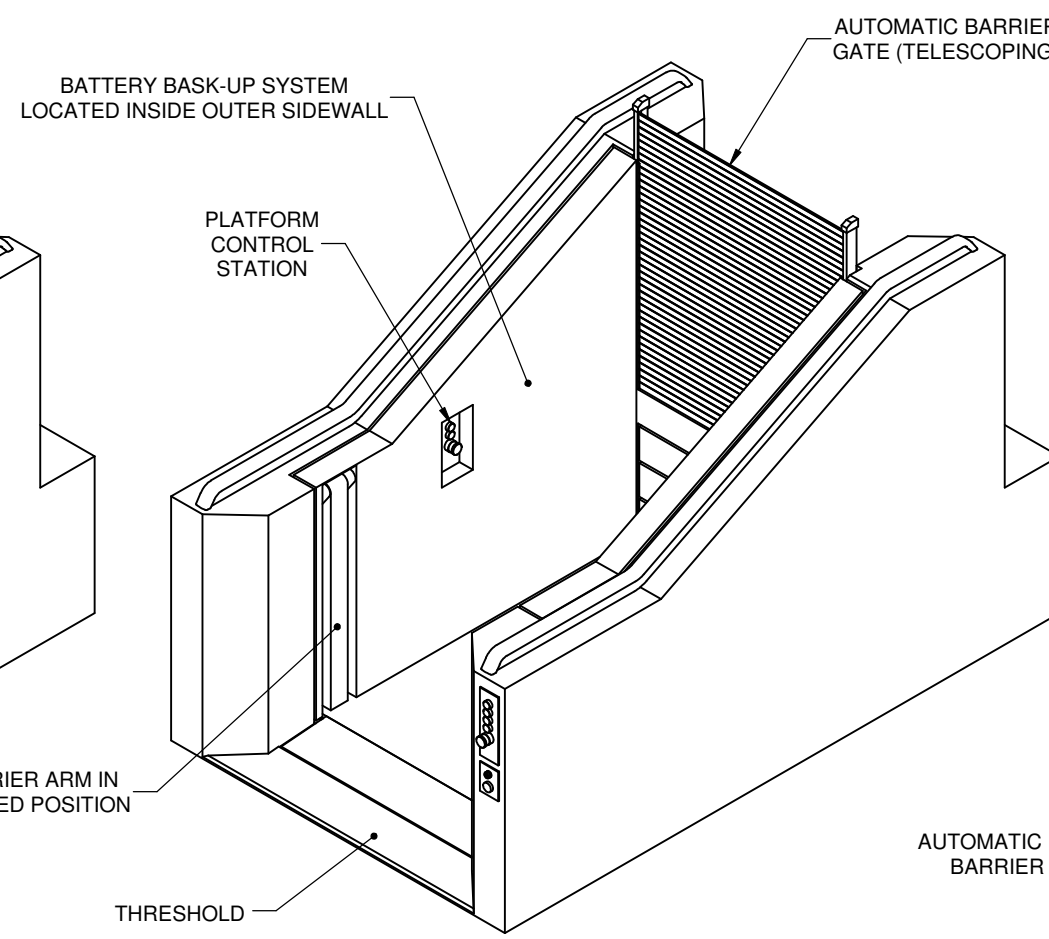

**STEPS RETRACTED
READY FOR PASSENGER INGRESS OR EGRESS**

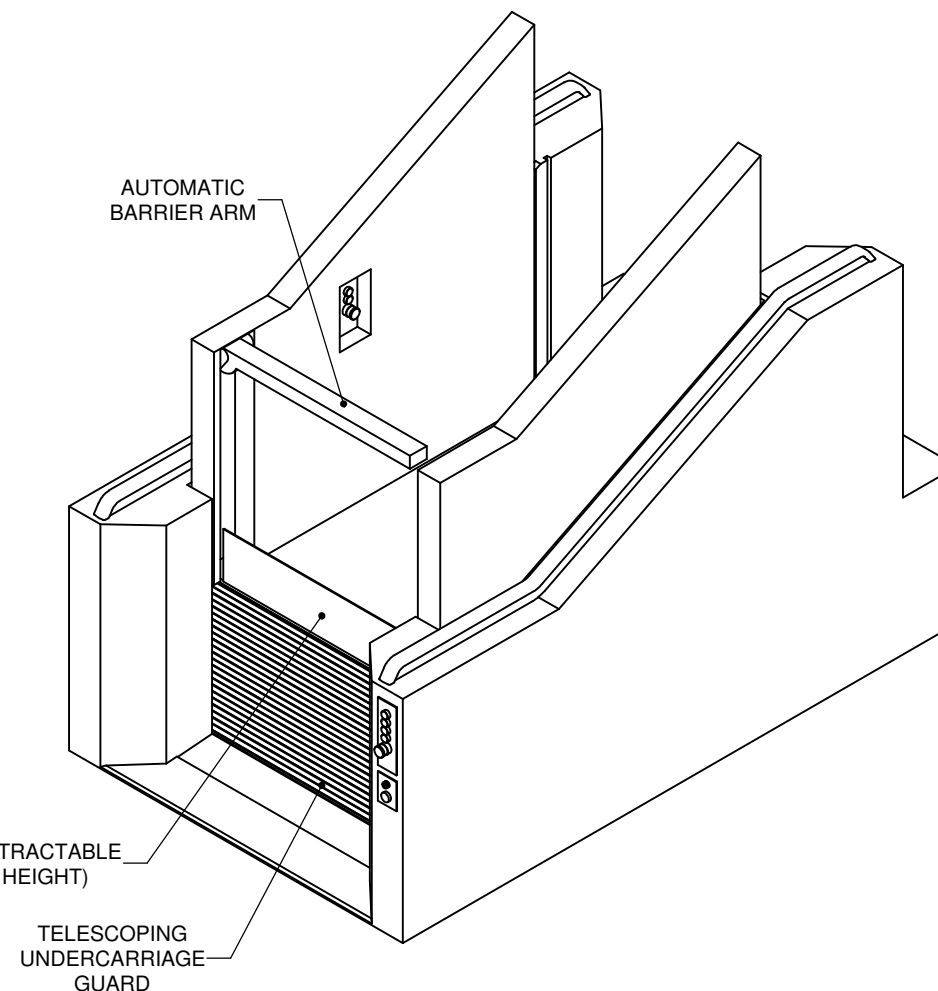

**LIFT PLATFORM AT UPPER LANDING
READY FOR PASSENGER INGRESS OR EGRESS**

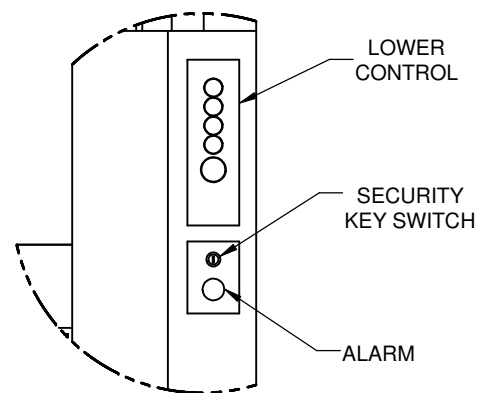

DETAIL A

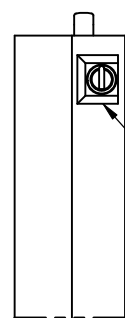

**SECTION B-B
VIEW ROTATED FOR CLARITY**

DISCONNECT SWITCH LOCATED AT UPPER LANDING. SEE DRAWING 910-0059 FOR J-BOX LOCATION AND PROVISIONS FOR SOURCE POWER.

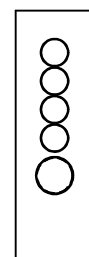

UPPER CONTROLS STATION

REFERENCE ONLY

SEE DRAWING 910-0059 FOR MOUNTING INFORMATION



A DIVISION OF
HOGAN MFG., INC.

THIS DOCUMENT IS AND CONTAINS CONFIDENTIAL TRADE SECRET INFORMATION OF THE COMPANY. NO PART OF IT MAY BE REPRODUCED, STORED IN A RETRIEVAL SYSTEM, OR TRANSMITTED IN ANY FORM OR BY ANY MEANS ELECTRONICALLY, PHOTOCOPIING, RECORDING OR OTHERWISE, WITHOUT THE PRIOR WRITTEN PERMISSION OF HOGAN MFG., INC. THIS DOCUMENT IS LOANED FOR THE LIMITED PURPOSES STATED HEREIN ONLY, AND REMAINS THE PROPERTY OF THE COMPANY.

TITLE LIFT CONFIGURATION, 3-STEP

DOCUMENT NO. 910-0081

SHEET NO. 2 OF 2

REVISION B

REVISIONS									
LTR	ECO	APPD	DATE	DESCRIPTION	DFTR	DATE	CHKR	DATE	
A				RELEASED	CAL	3/13/2009			
B				ADDED 60" TURNING SPACE, NOTES & SHEET 2	BSA	10/18/2011			

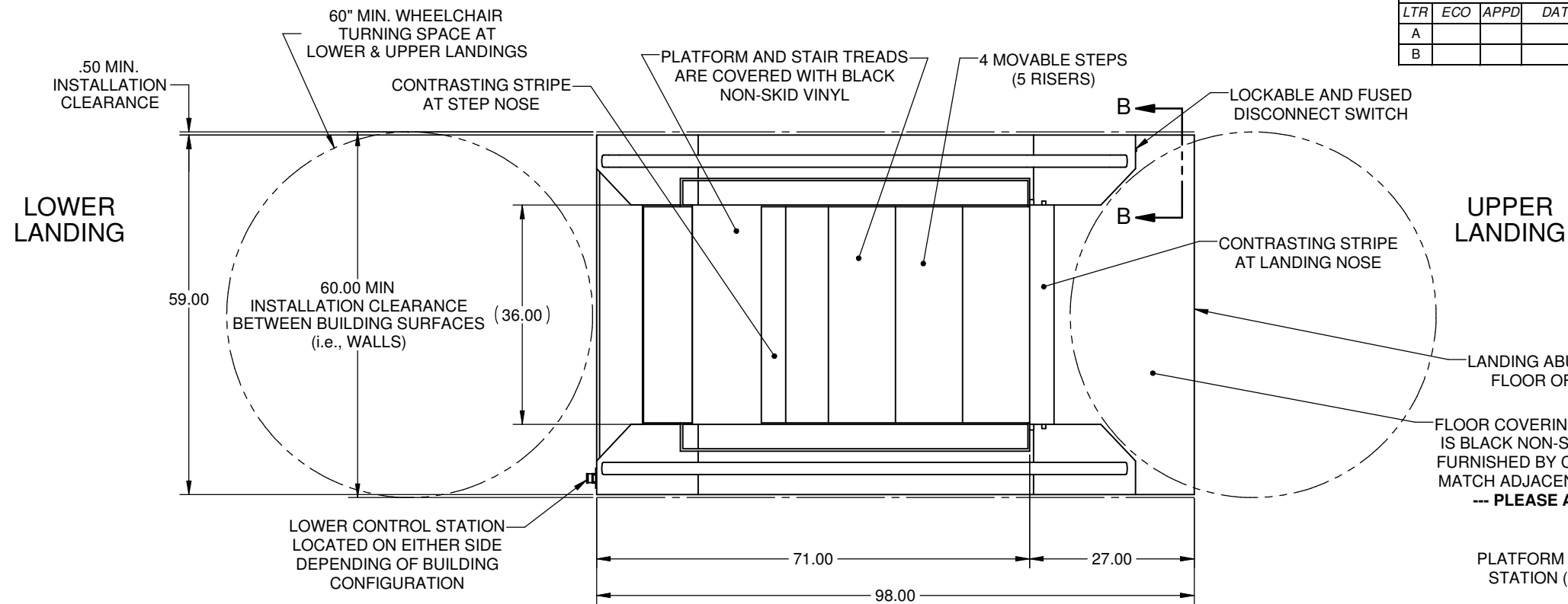

NOTES:

1. THIS DRAWING IS SUBJECT TO CHANGE PENDING APPLICABLE STATE AND LOCAL CODES, AND CUSTOMER APPROVAL.
2. CUSTOMER MUST PROVIDE APPLICABLE STATE AND LOCAL CODES TO LIFT-U PRIOR TO DESIGN.
3. DRAWING MUST BE SIGNED BY CUSTOMER AND RETURNED TO LIFT-U PRIOR TO PRODUCTION RELEASE. CUSTOMER APPROVAL SIGNIFIES THAT ALL DIMENSIONS ARE CORRECT TO THEIR SPECIFICATIONS.
4. SEE SHEET 2 OF 3 FOR LIFT SPECIFICATIONS.

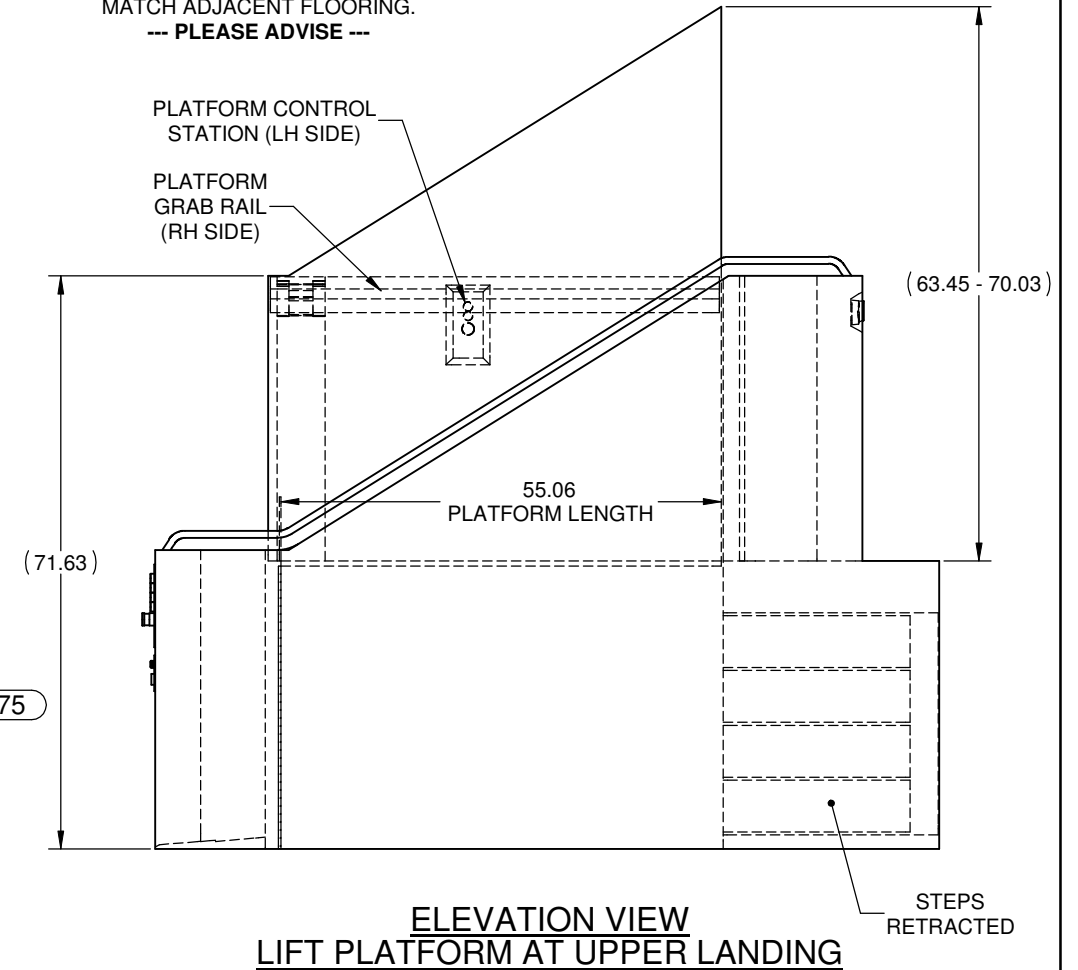
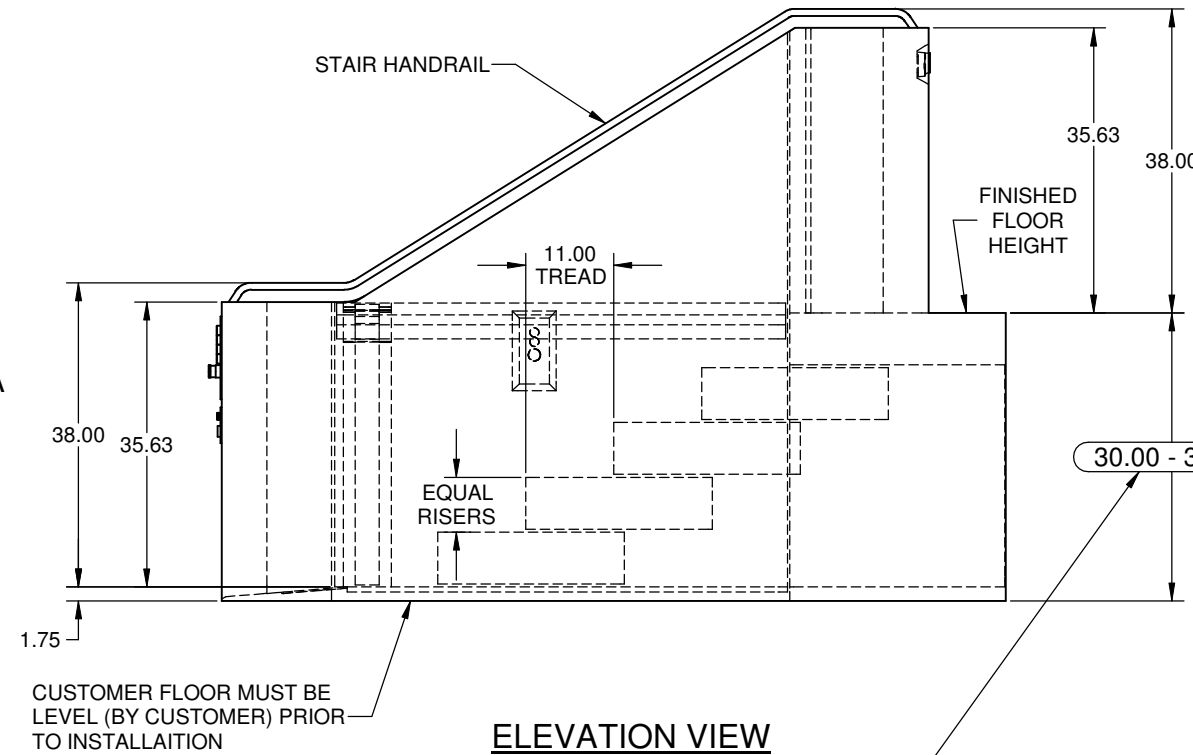
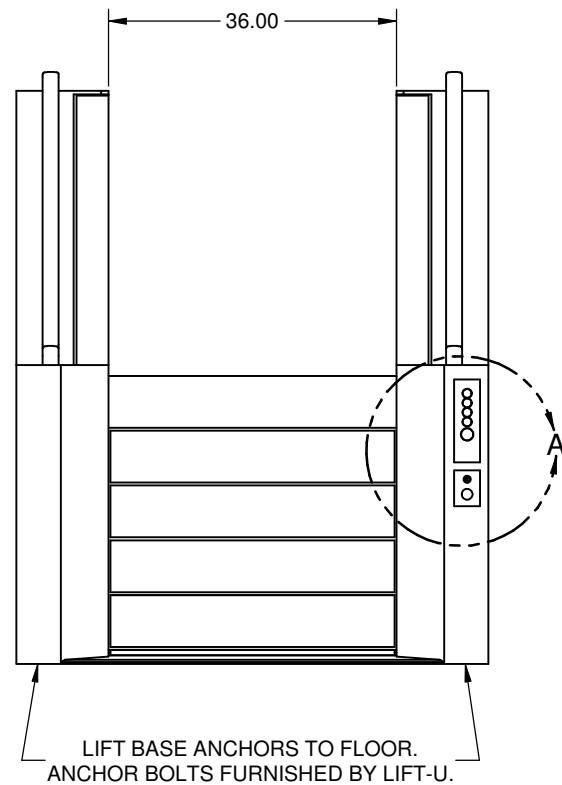

**APPROVAL NOTE:
CONTRACTOR MUST VERIFY LANDING HEIGHT
PRIOR TO RELEASE FOR FABRICATION.
MEASUREMENT TO BE TAKEN FROM BASE FLOOR
AT THE LOWER LANDING TO THE FINISH FLOOR
AT THE UPPER LANDING.**

LIFT-U
P.O. BOX 398
ESCALON, CA. 95320
209-838-2400

A DIVISION OF
HOGAN MFG., INC.

THIS DOCUMENT IS AND CONTAINS CONFIDENTIAL TRADE SECRET INFORMATION OF THE COMPANY. NO PART OF IT MAY BE REPRODUCED, STORED IN A RETRIEVAL SYSTEM, OR TRANSMITTED IN ANY FORM OR BY ANY MEANS ELECTRONICALLY, PHOTOCOPYING, RECORDING OR OTHERWISE, WITHOUT THE PRIOR WRITTEN PERMISSION OF HOGAN MFG., INC. THIS DOCUMENT IS LOANED FOR THE LIMITED PURPOSES STATED HEREIN ONLY, AND REMAINS THE PROPERTY OF THE COMPANY.

TITLE LIFT CONFIGURATION, 4-STEP

DOCUMENT NO. 910-0082

SHEET NO. 1 OF 2

REVISION B

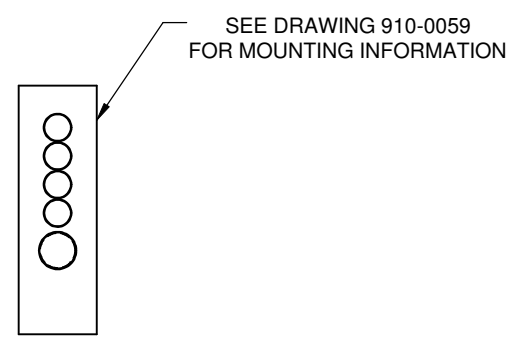
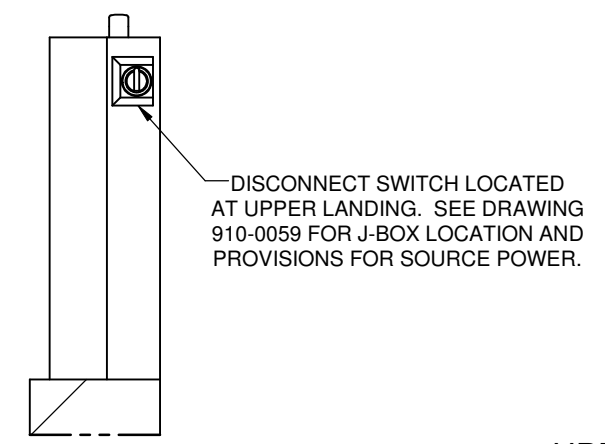
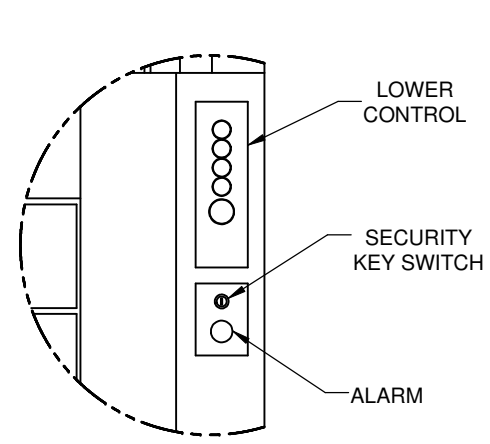
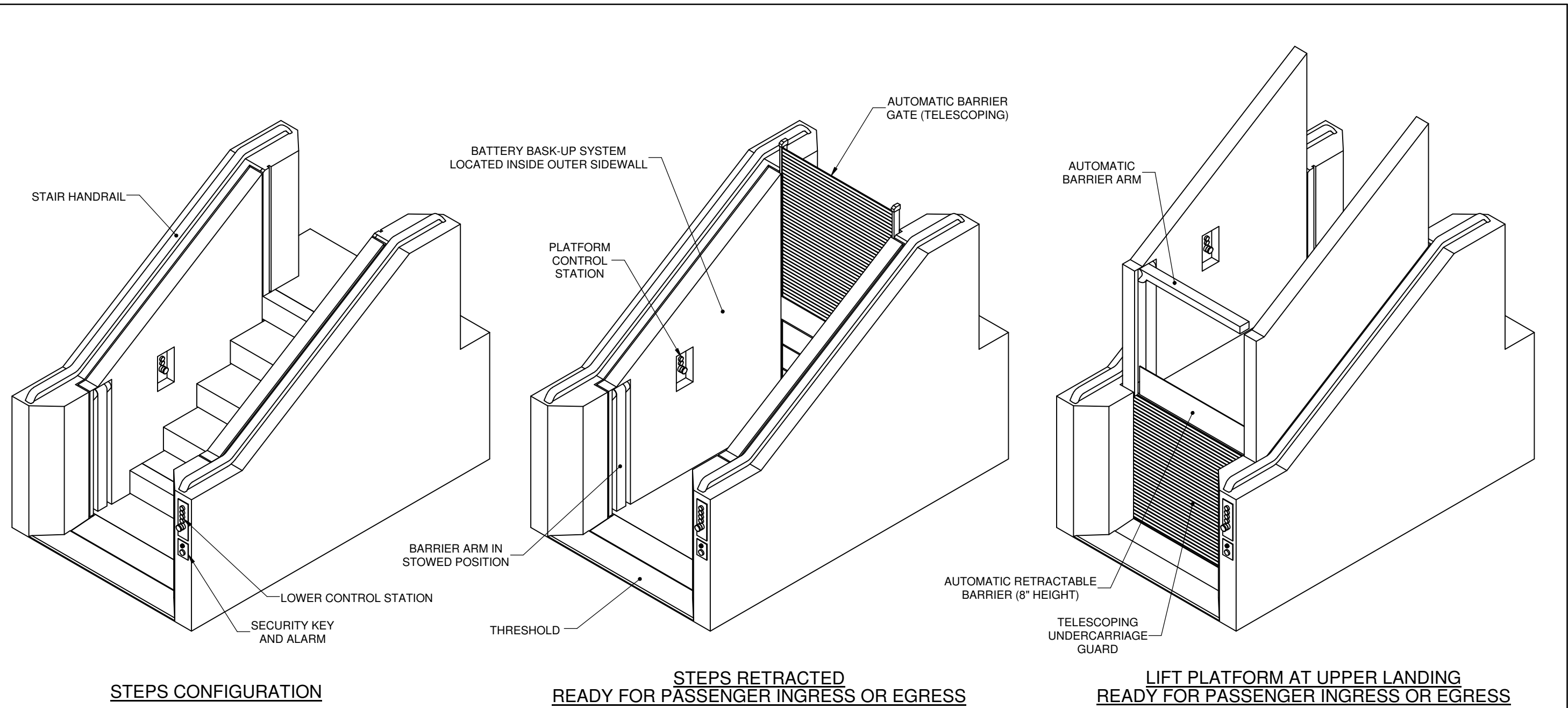

 LIFT-U P.O. BOX 398 ESCALON, CA. 95320 209-838-2400	THIS DOCUMENT IS AND CONTAINS CONFIDENTIAL TRADE SECRET INFORMATION OF THE COMPANY. NO PART OF IT MAY BE REPRODUCED, STORED IN A RETRIEVAL SYSTEM, OR TRANSMITTED IN ANY FORM OR BY ANY MEANS ELECTRONICALLY, PHOTOCOPYING, RECORDING OR OTHERWISE, WITHOUT THE PRIOR WRITTEN PERMISSION OF HOGAN MFG., INC. THIS DOCUMENT IS LOANED FOR THE LIMITED PURPOSES STATED HEREIN ONLY, AND REMAINS THE PROPERTY OF THE COMPANY.		
	A DIVISION OF HOGAN MFG., INC.		
TITLE LIFT CONFIGURATION, 4-STEP			
DOCUMENT NO. 910-0082	SHEET NO. 2 OF 2	REVISION B	

REVISIONS									
LTR	ECO	APPD	DATE	DESCRIPTION	DFTR	DATE	CHKR	DATE	
A				RELEASED	CAL	3/13/2009			
B				ADDED 60" TURNING SPACE, NOTES & SHEET 2	BSA	10/18/2011			

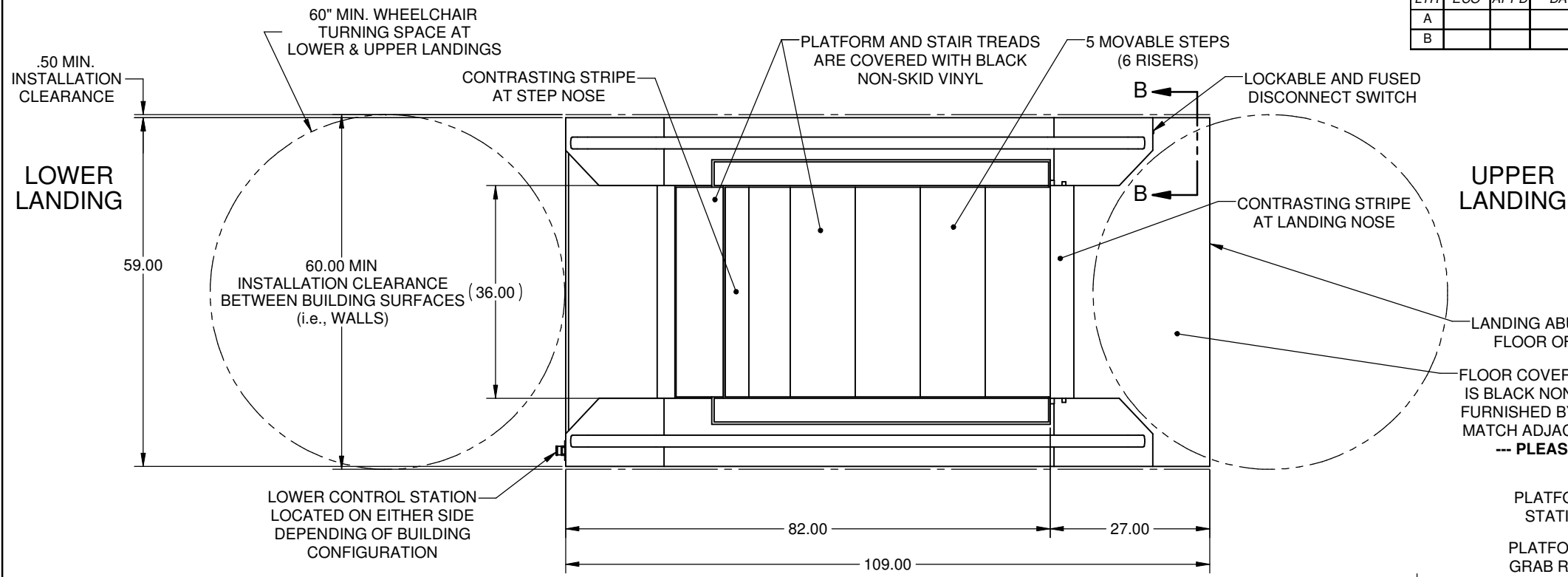

- NOTES:**
1. THIS DRAWING IS SUBJECT TO CHANGE PENDING APPLICABLE STATE AND LOCAL CODES, AND CUSTOMER APPROVAL.
 2. CUSTOMER MUST PROVIDE APPLICABLE STATE AND LOCAL CODES TO LIFT-U PRIOR TO DESIGN.
 3. DRAWING MUST BE SIGNED BY CUSTOMER AND RETURNED TO LIFT-U PRIOR TO PRODUCTION RELEASE. CUSTOMER APPROVAL SIGNIFIES THAT ALL DIMENSIONS ARE CORRECT TO THEIR SPECIFICATIONS.
 4. SEE SHEET 2 OF 3 FOR LIFT SPECIFICATIONS.

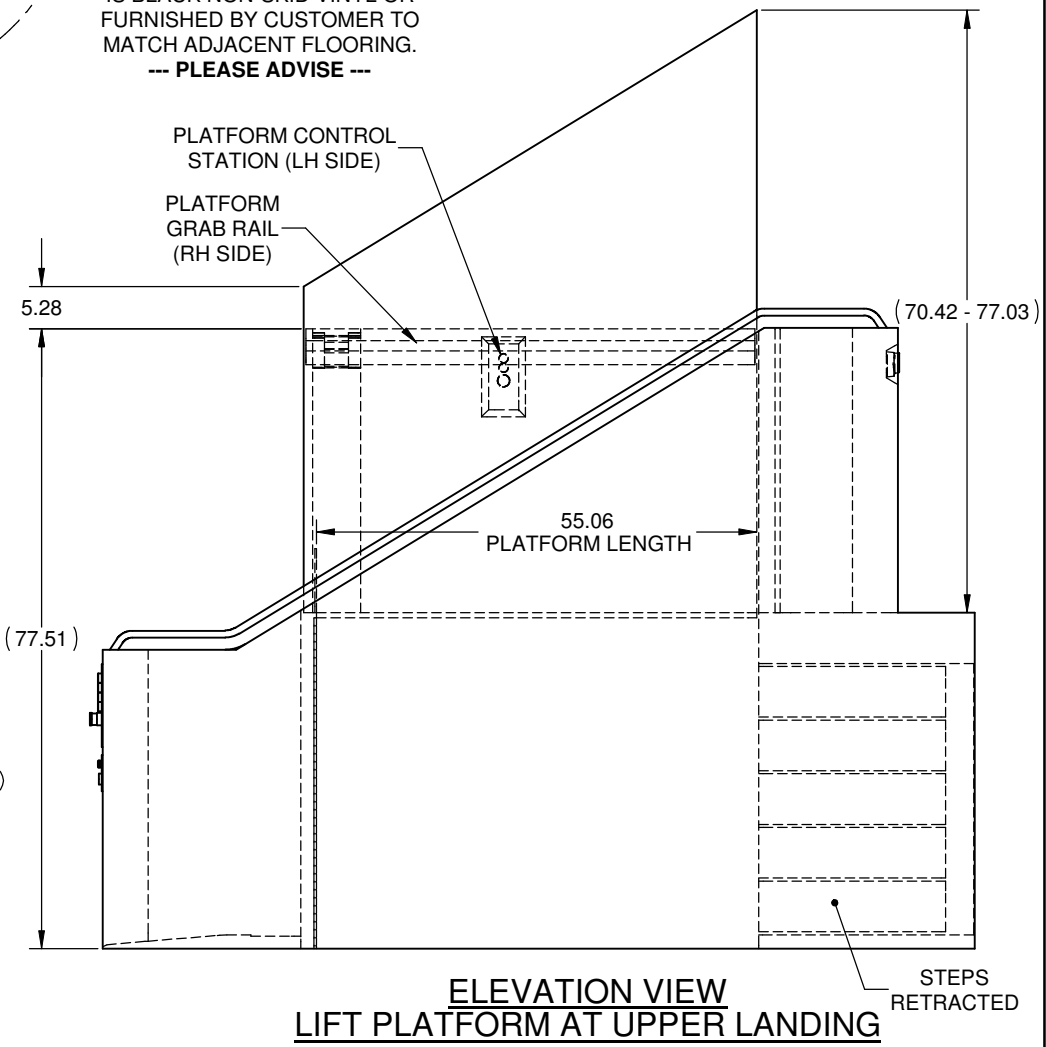
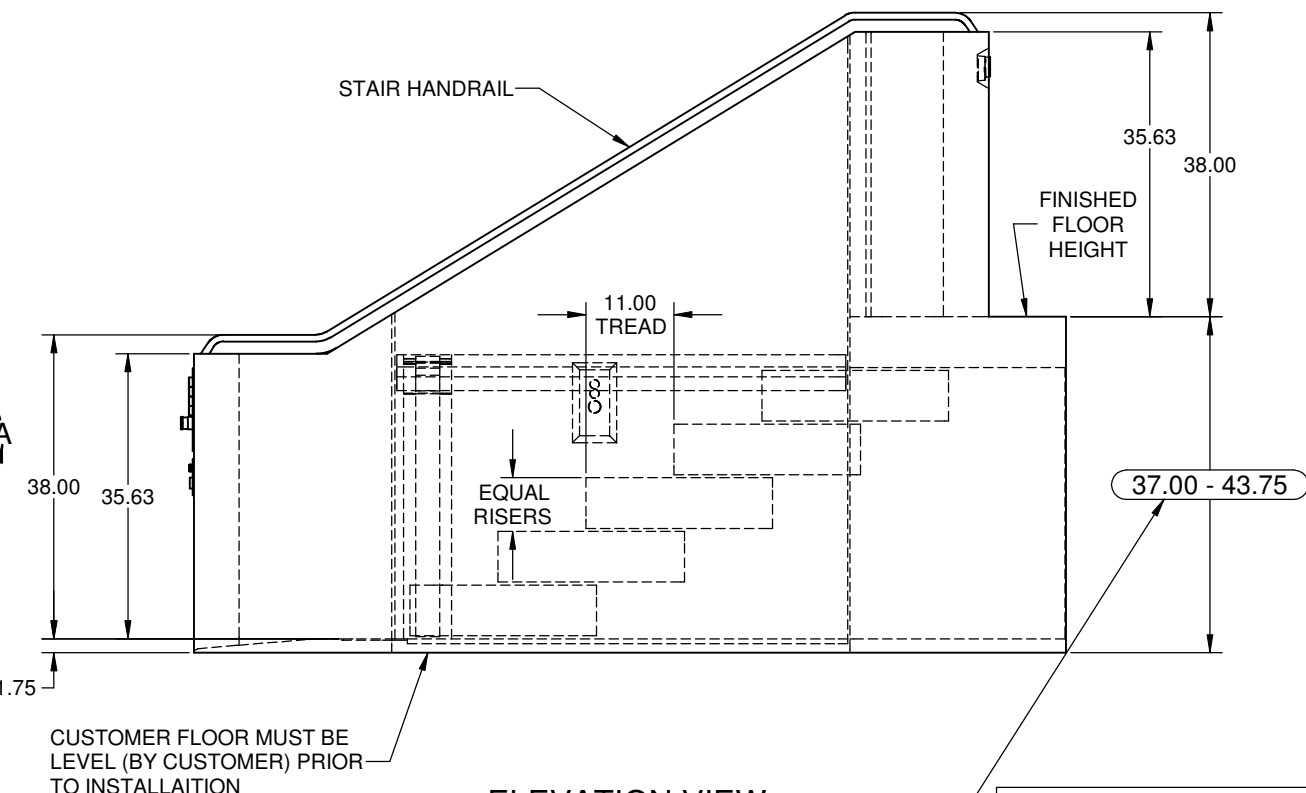
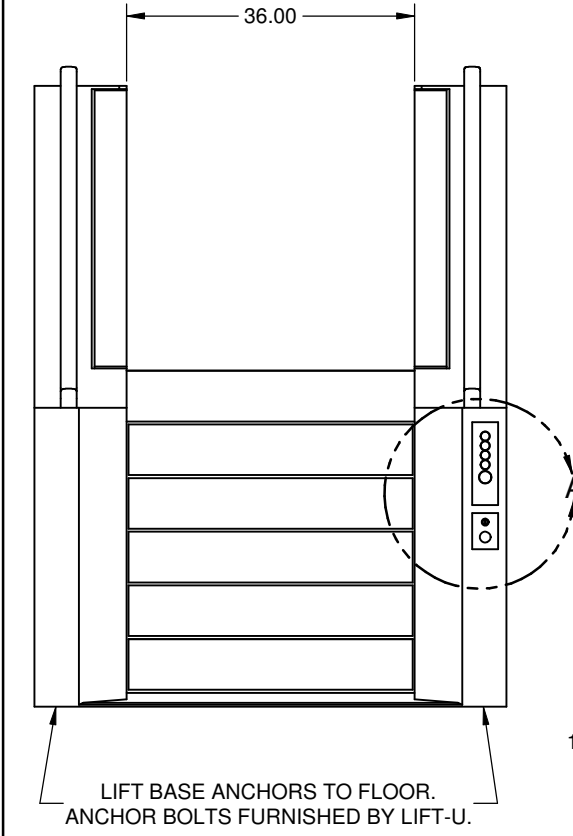

APPROVAL NOTE:
CONTRACTOR MUST VERIFY LANDING HEIGHT PRIOR TO RELEASE FOR FABRICATION. MEASUREMENT TO BE TAKEN FROM BASE FLOOR AT THE LOWER LANDING TO THE FINISH FLOOR AT THE UPPER LANDING.

LIFT-U
 P.O. BOX 398
 ESCALON, CA. 95320
 209-838-2400

A DIVISION OF
HOGAN MFG., INC.

THIS DOCUMENT IS AND CONTAINS CONFIDENTIAL TRADE SECRET INFORMATION OF THE COMPANY. NO PART OF IT MAY BE REPRODUCED, STORED IN A RETRIEVAL SYSTEM, OR TRANSMITTED IN ANY FORM OR BY ANY MEANS ELECTRONICALLY, PHOTOCOPIING, RECORDING OR OTHERWISE, WITHOUT THE PRIOR WRITTEN PERMISSION OF HOGAN MFG, INC. THIS DOCUMENT IS LOANED FOR THE LIMITED PURPOSES STATED HEREIN ONLY, AND REMAINS THE PROPERTY OF THE COMPANY.

TITLE			
LIFT CONFIGURATION, 5-STEP			
DOCUMENT NO.	910-0083	SHEET NO.	1 OF 2
		REVISION	B

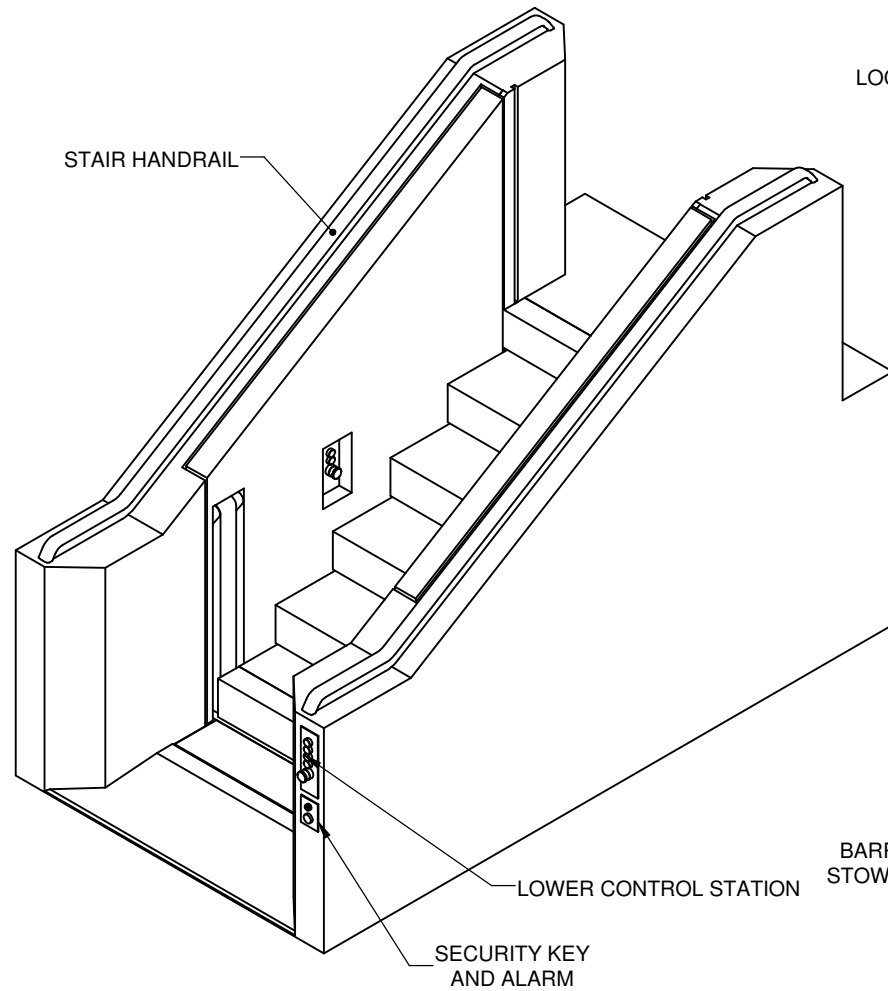

STEPS CONFIGURATION

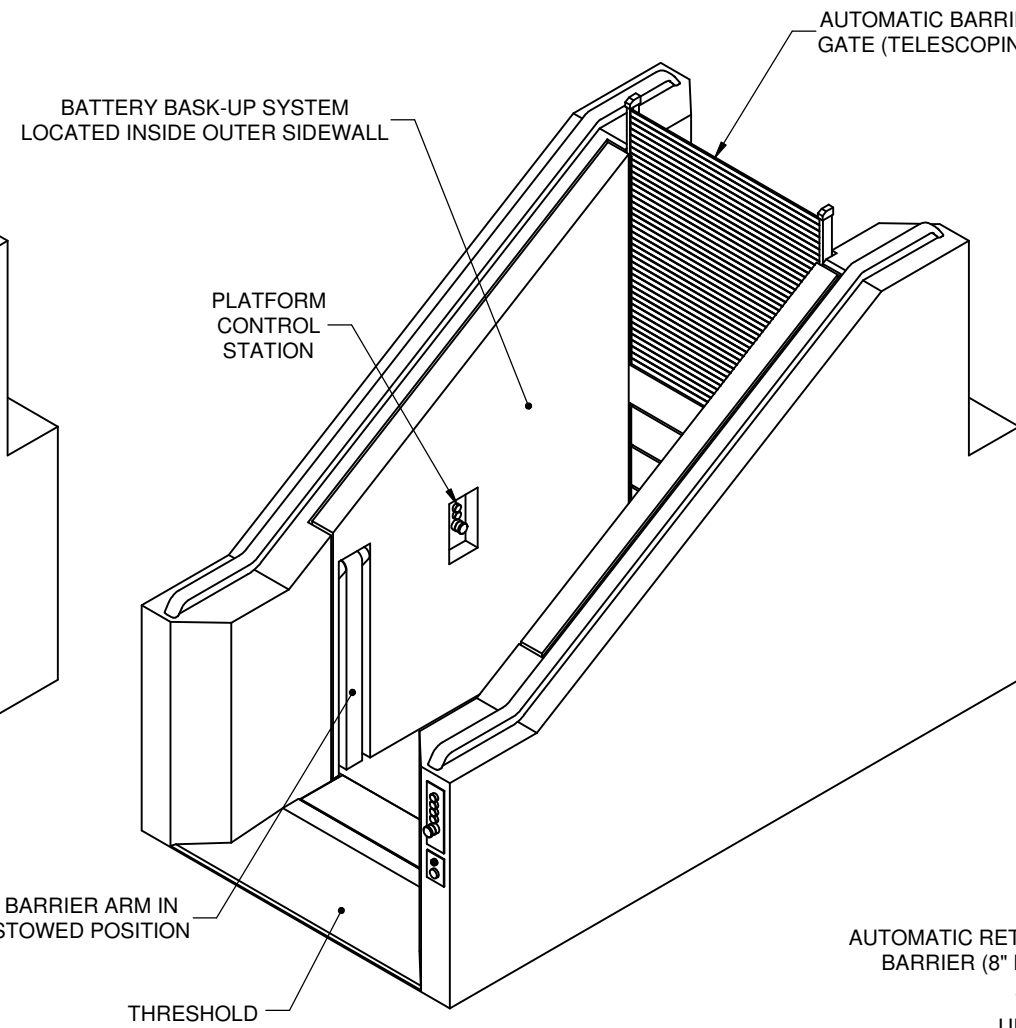

**STEPS RETRACTED
READY FOR PASSENGER INGRESS OR EGRESS**

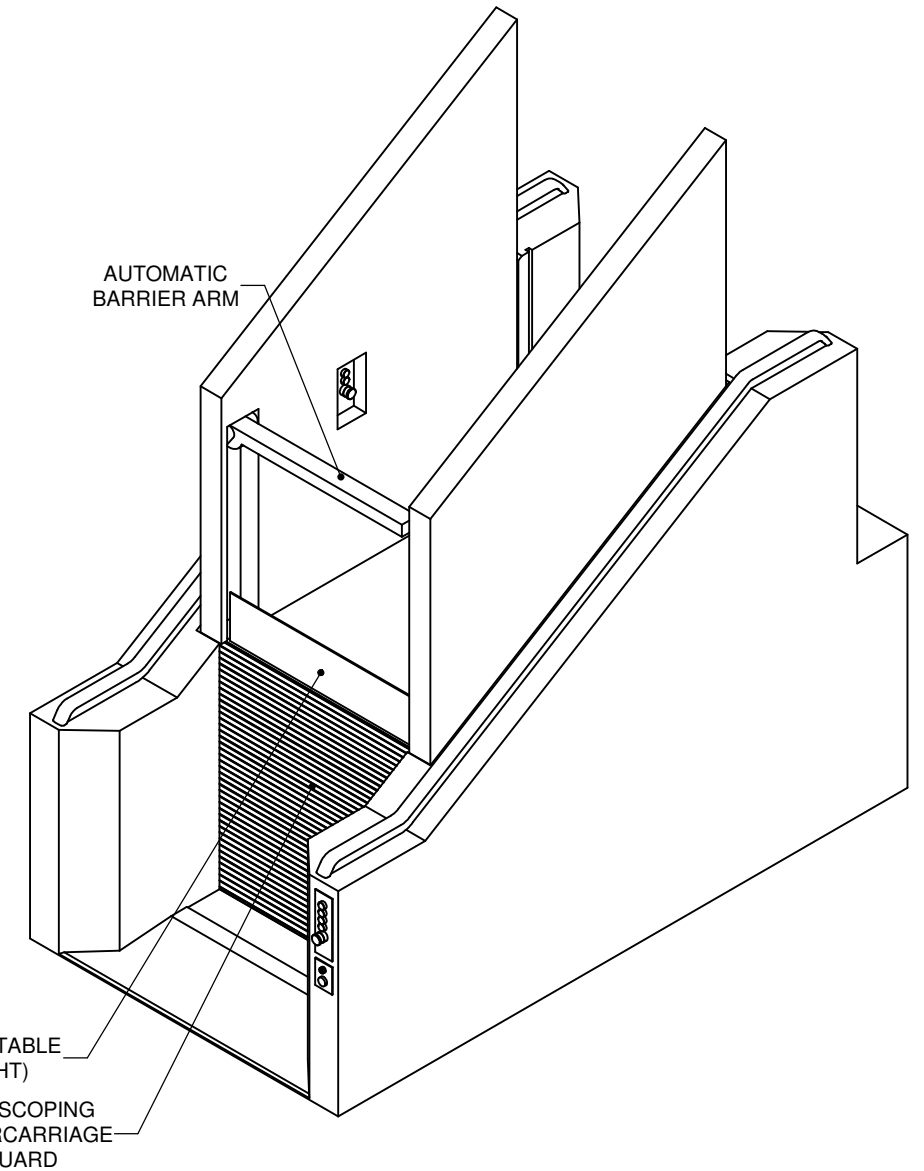

**LIFT PLATFORM AT UPPER LANDING
READY FOR PASSENGER INGRESS OR EGRESS**

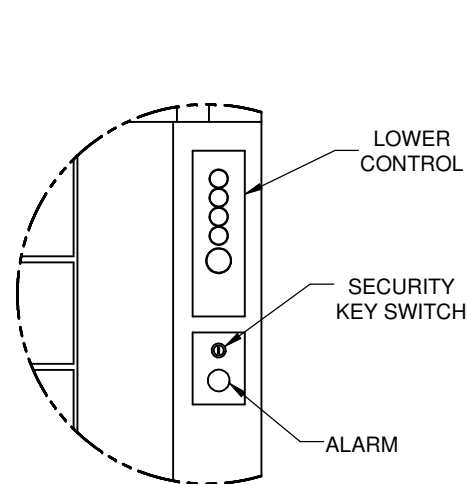

DETAIL A

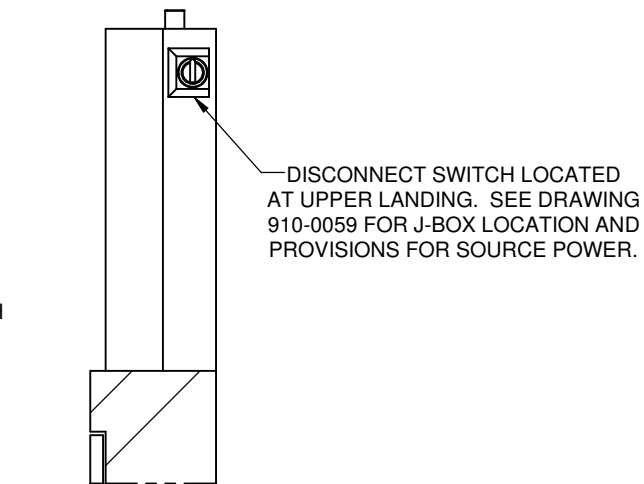

**SECTION B-B
VIEW ROTATED FOR CLARITY**

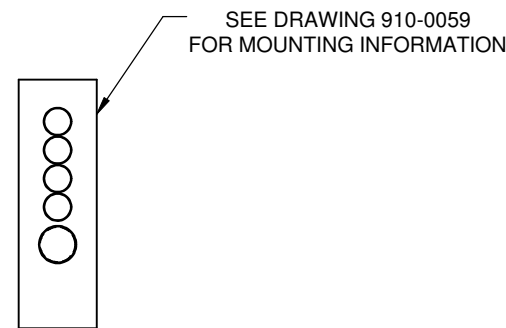

**UPPER CONTROLS STATION
REFERENCE ONLY**



LIFT-U
P.O. BOX 398
ESCALON, CA. 95320
209-838-2400

THIS DOCUMENT IS AND CONTAINS CONFIDENTIAL TRADE SECRET INFORMATION OF THE COMPANY. NO PART OF IT MAY BE REPRODUCED, STORED IN A RETRIEVAL SYSTEM, OR TRANSMITTED IN ANY FORM OR BY ANY MEANS ELECTRONICALLY, PHOTOCOPYING, RECORDING OR OTHERWISE, WITHOUT THE PRIOR WRITTEN PERMISSION OF HOGAN MFG., INC. THIS DOCUMENT IS LOANED FOR THE LIMITED PURPOSES STATED HEREIN ONLY, AND REMAINS THE PROPERTY OF THE COMPANY.

A DIVISION OF HOGAN MFG., INC.		TITLE LIFT CONFIGURATION, 5-STEP	
DOCUMENT NO. 910-0083	SHEET NO. 2 OF 2	REVISION B	

REVISIONS									
LTR	ECO	APPD	DATE	DESCRIPTION	DFTR	DATE	CHKR	DATE	
A				RELEASED	CAL	3/13/2009			
B				ADDED 60" TURNING SPACE, NOTES & SHEET 2	BSA	10/18/2011			

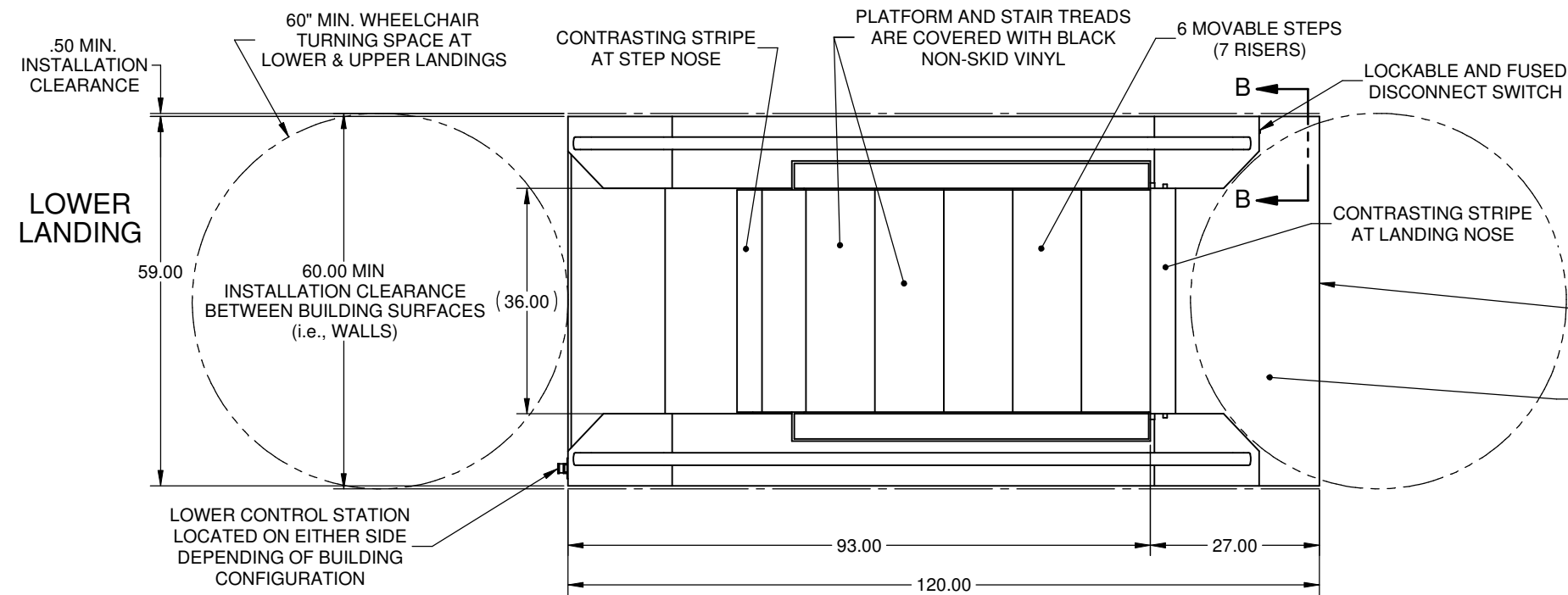

- NOTES:**
1. THIS DRAWING IS SUBJECT TO CHANGE PENDING APPLICABLE STATE AND LOCAL CODES, AND CUSTOMER APPROVAL.
 2. CUSTOMER MUST PROVIDE APPLICABLE STATE AND LOCAL CODES TO LIFT-U PRIOR TO DESIGN.
 3. DRAWING MUST BE SIGNED BY CUSTOMER AND RETURNED TO LIFT-U PRIOR TO PRODUCTION RELEASE. CUSTOMER APPROVAL SIGNIFIES THAT ALL DIMENSIONS ARE CORRECT TO THEIR SPECIFICATIONS.
 4. SEE SHEET 2 OF 3 FOR LIFT SPECIFICATIONS.

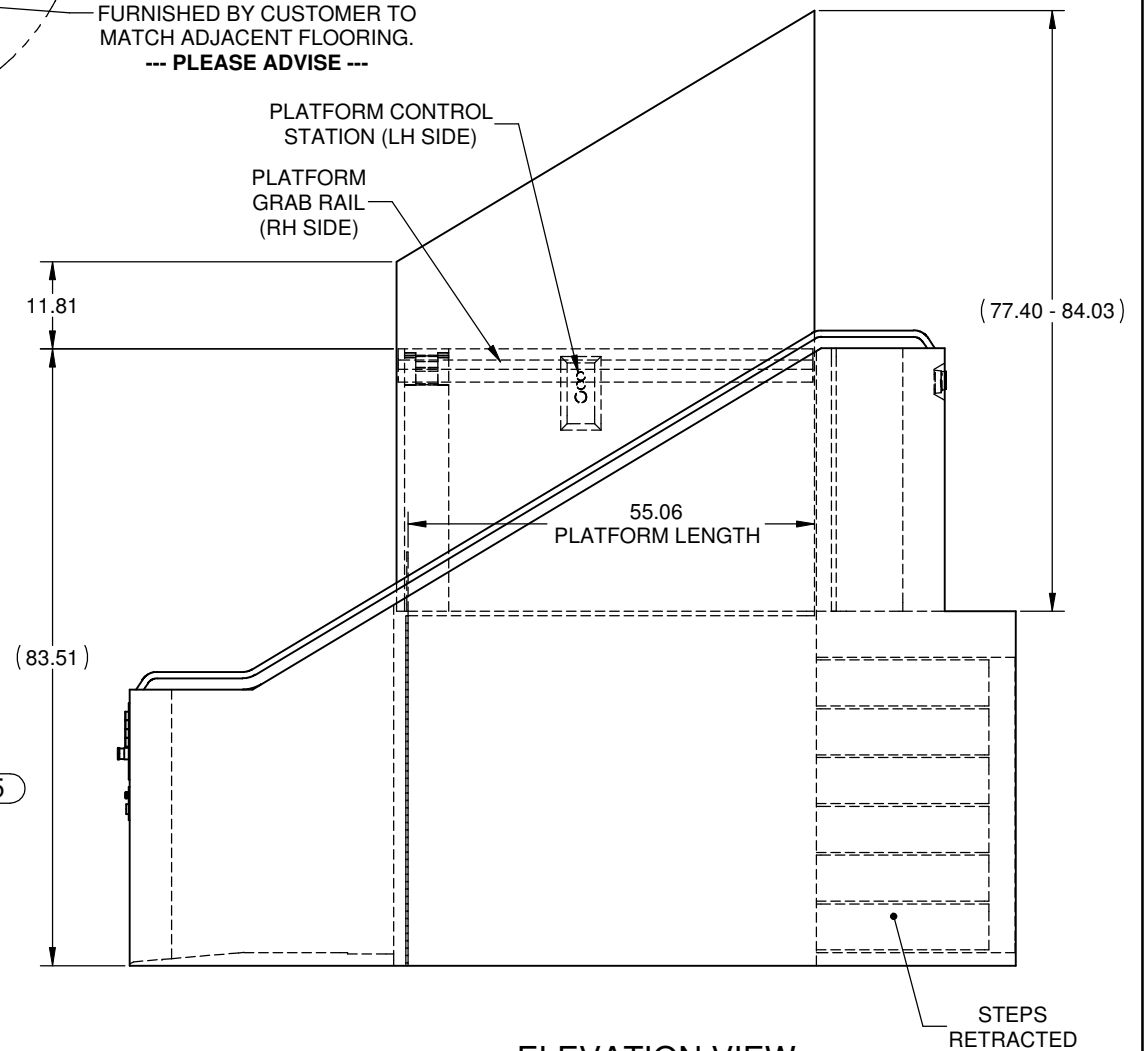
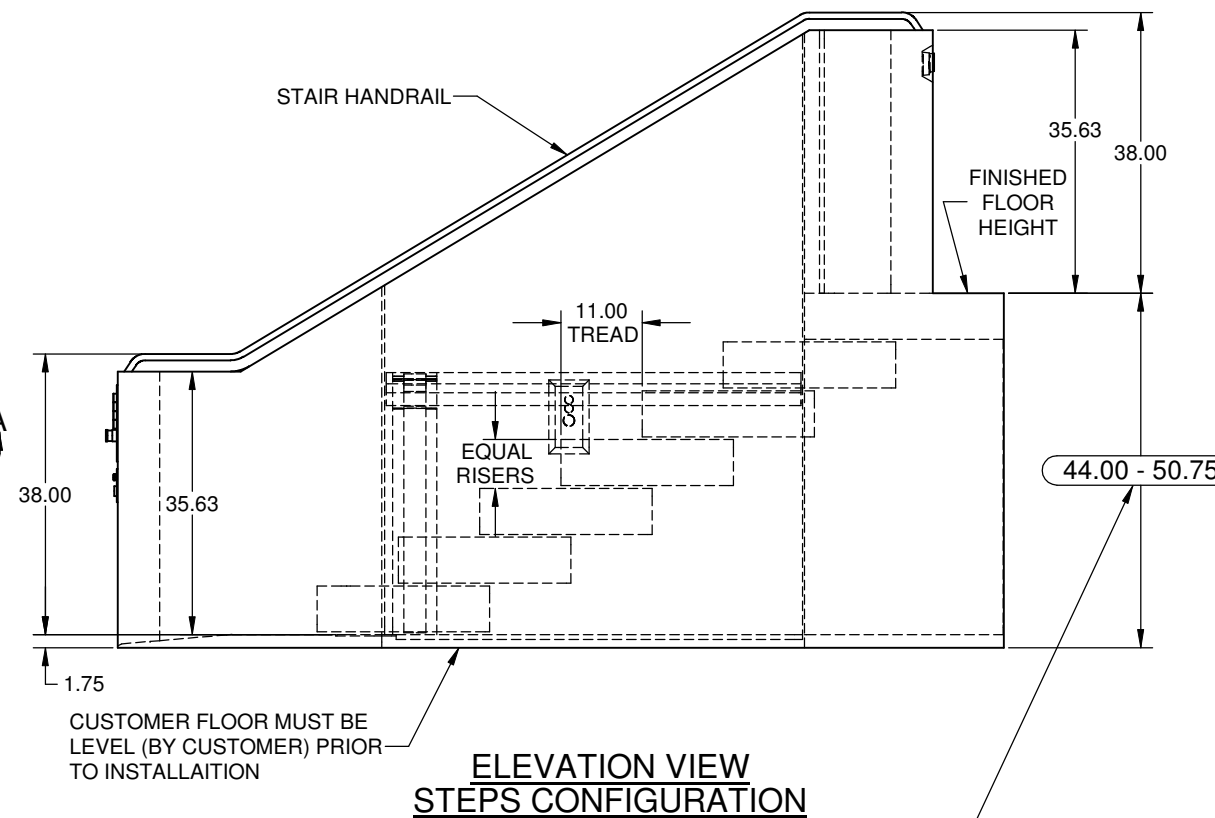
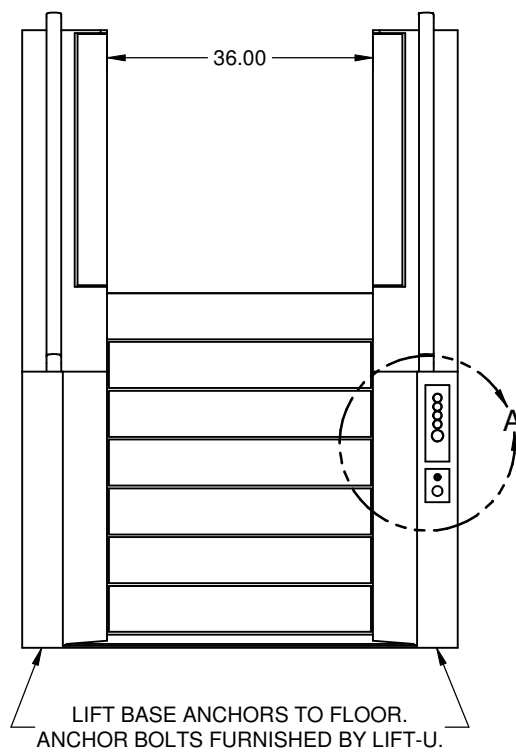

APPROVAL NOTE:
CONTRACTOR MUST VERIFY LANDING HEIGHT PRIOR TO RELEASE FOR FABRICATION. MEASUREMENT TO BE TAKEN FROM BASE FLOOR AT THE LOWER LANDING TO THE FINISH FLOOR AT THE UPPER LANDING.

LIFT-U
 P.O. BOX 398
 ESCALON, CA. 95320
 209-838-2400

A DIVISION OF
HOGAN MFG., INC.

THIS DOCUMENT IS AND CONTAINS CONFIDENTIAL TRADE SECRET INFORMATION OF THE COMPANY. NO PART OF IT MAY BE REPRODUCED, STORED IN A RETRIEVAL SYSTEM, OR TRANSMITTED IN ANY FORM OR BY ANY MEANS ELECTRONICALLY, PHOTOCOPIING, RECORDING OR OTHERWISE, WITHOUT THE PRIOR WRITTEN PERMISSION OF HOGAN MFG., INC. THIS DOCUMENT IS LOANED FOR THE LIMITED PURPOSES STATED HEREIN ONLY, AND REMAINS THE PROPERTY OF THE COMPANY.

TITLE LIFT CONFIGURATION, 6-STEP

DOCUMENT NO. 910-0084 **SHEET NO.** 1 OF 2 **REVISION** B

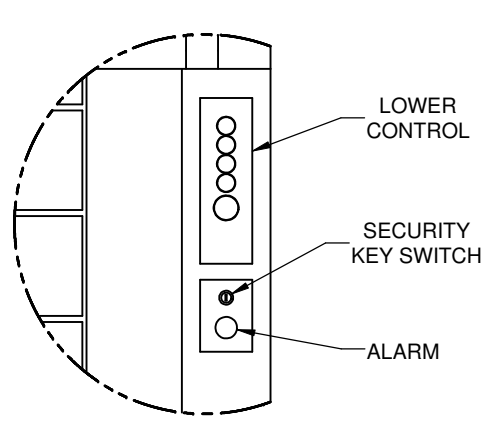
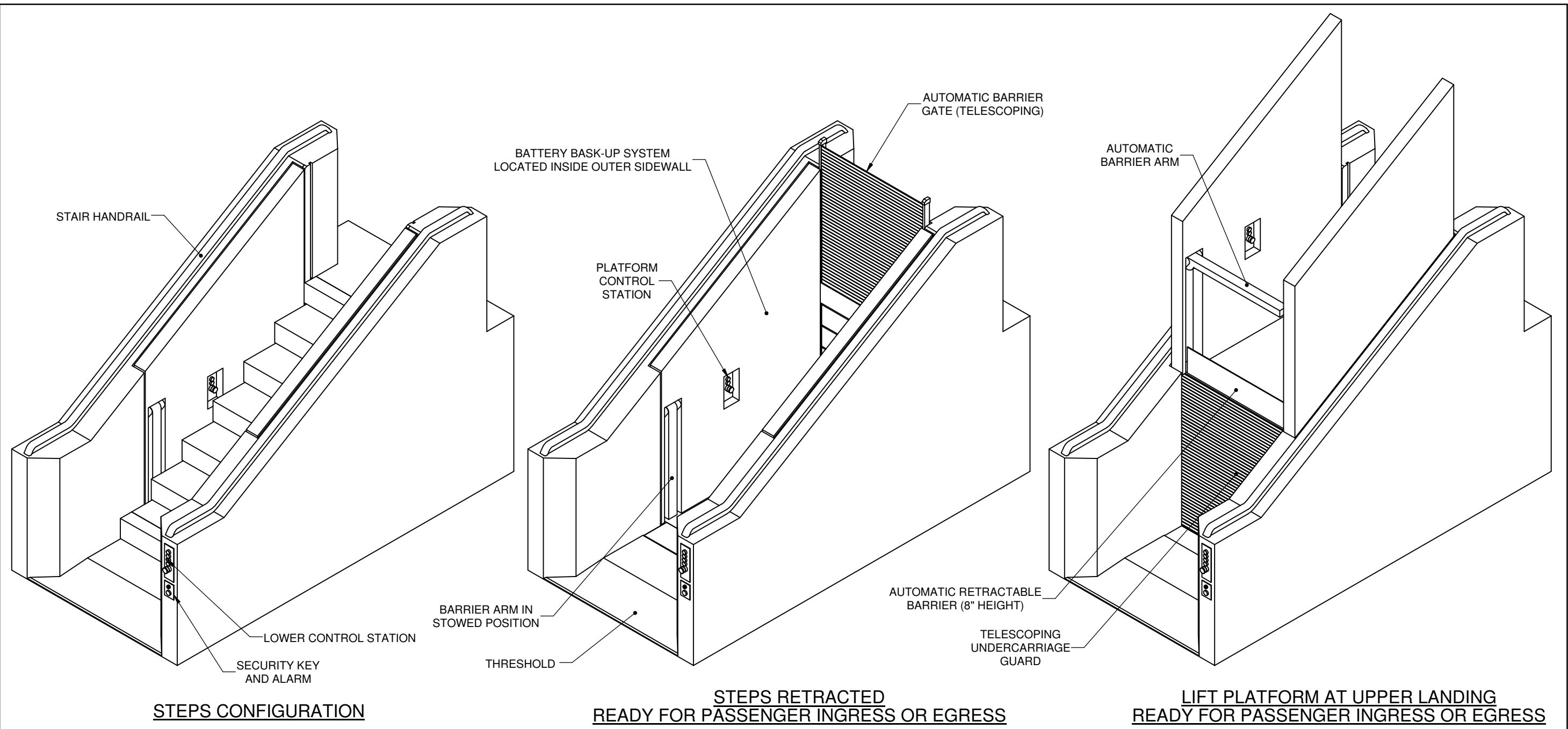

DETAIL A

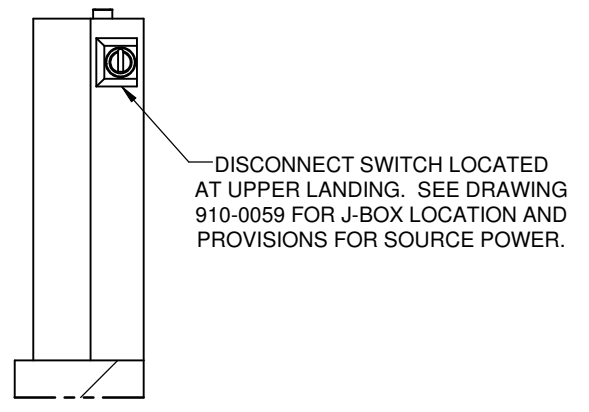

**SECTION B-B
VIEW ROTATED FOR CLARITY**

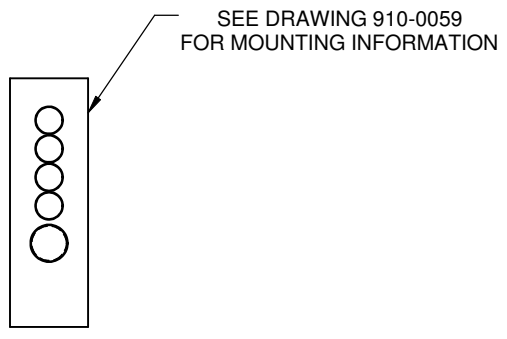

**UPPER CONTROLS STATION
REFERENCE ONLY**

LIFT-U
 P.O. BOX 398
 ESCALON, CA. 95320
 209-838-2400

A DIVISION OF
HOGAN MFG., INC.

THIS DOCUMENT IS AND CONTAINS CONFIDENTIAL TRADE SECRET INFORMATION OF THE COMPANY. NO PART OF IT MAY BE REPRODUCED, STORED IN A RETRIEVAL SYSTEM, OR TRANSMITTED IN ANY FORM OR BY ANY MEANS ELECTRONICALLY, PHOTOCOPYING, RECORDING OR OTHERWISE, WITHOUT THE PRIOR WRITTEN PERMISSION OF HOGAN MFG., INC. THIS DOCUMENT IS LOANED FOR THE LIMITED PURPOSES STATED HEREIN ONLY, AND REMAINS THE PROPERTY OF THE COMPANY.

TITLE	LIFT CONFIGURATION, 6-STEP		
DOCUMENT NO.	910-0084	SHEET NO.	2 OF 2
		REVISION	B