

REVISIONS									
LTR	ECO	APPD	DATE	DESCRIPTION	DFTR	DATE	CHKR	DATE	
A				RELEASED					

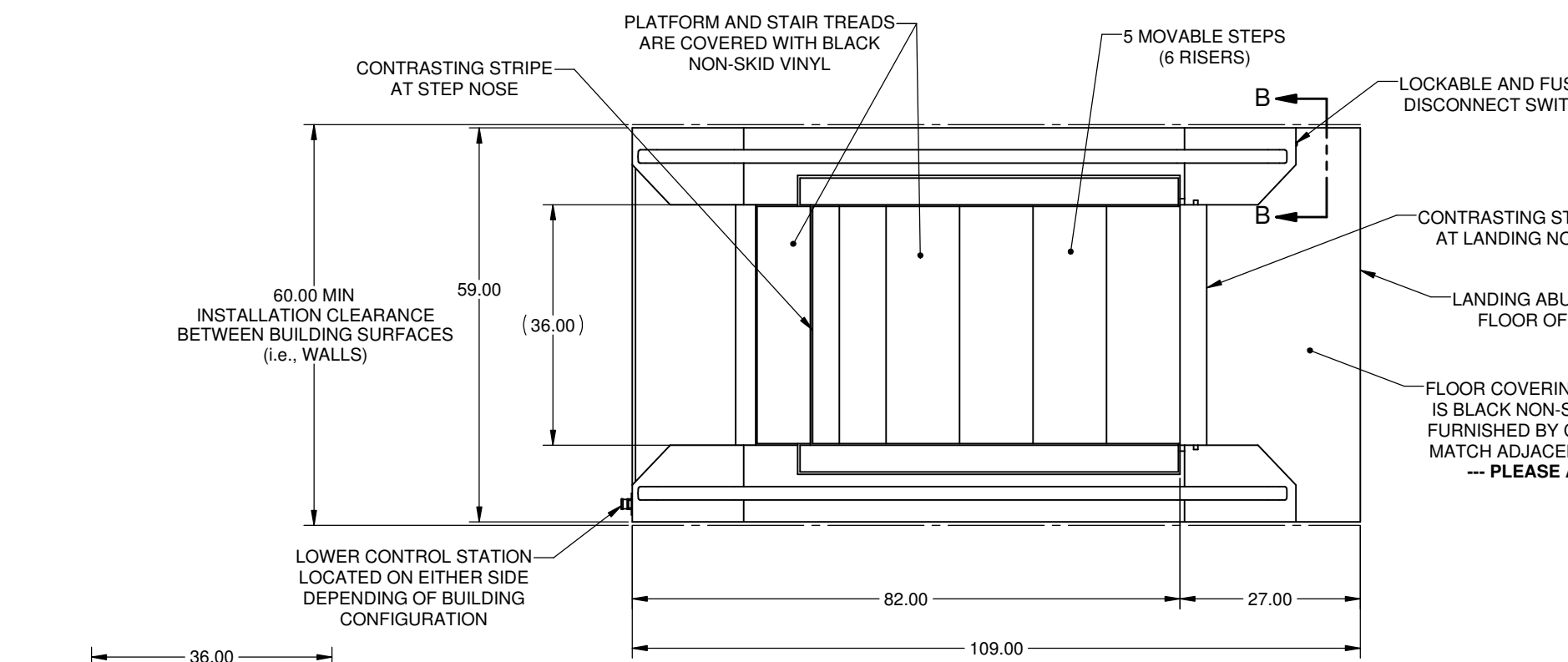

- NOTES:**
- 1) THIS DRAWING IS SUBJECT TO CHANGE PENDING APPLICABLE STATE AND LOCAL CODES, AND CUSTOMER APPROVAL.
 - 2) CUSTOMER MUST PROVIDE APPLICABLE STATE AND LOCAL CODES TO LIFT-U PRIOR TO DESIGN.
 - 3) DRAWING MUST BE SIGNED BY CUSTOMER AND RETURNED TO LIFT-U PRIOR TO PRODUCTION RELEASE. CUSTOMER APPROVAL SIGNIFIES THAT ALL DIMENSIONS ARE CORRECT TO THEIR SPECIFICATIONS.
 - 4) SEE SHEET 2 OF 3 FOR LIFT SPECIFICATIONS.

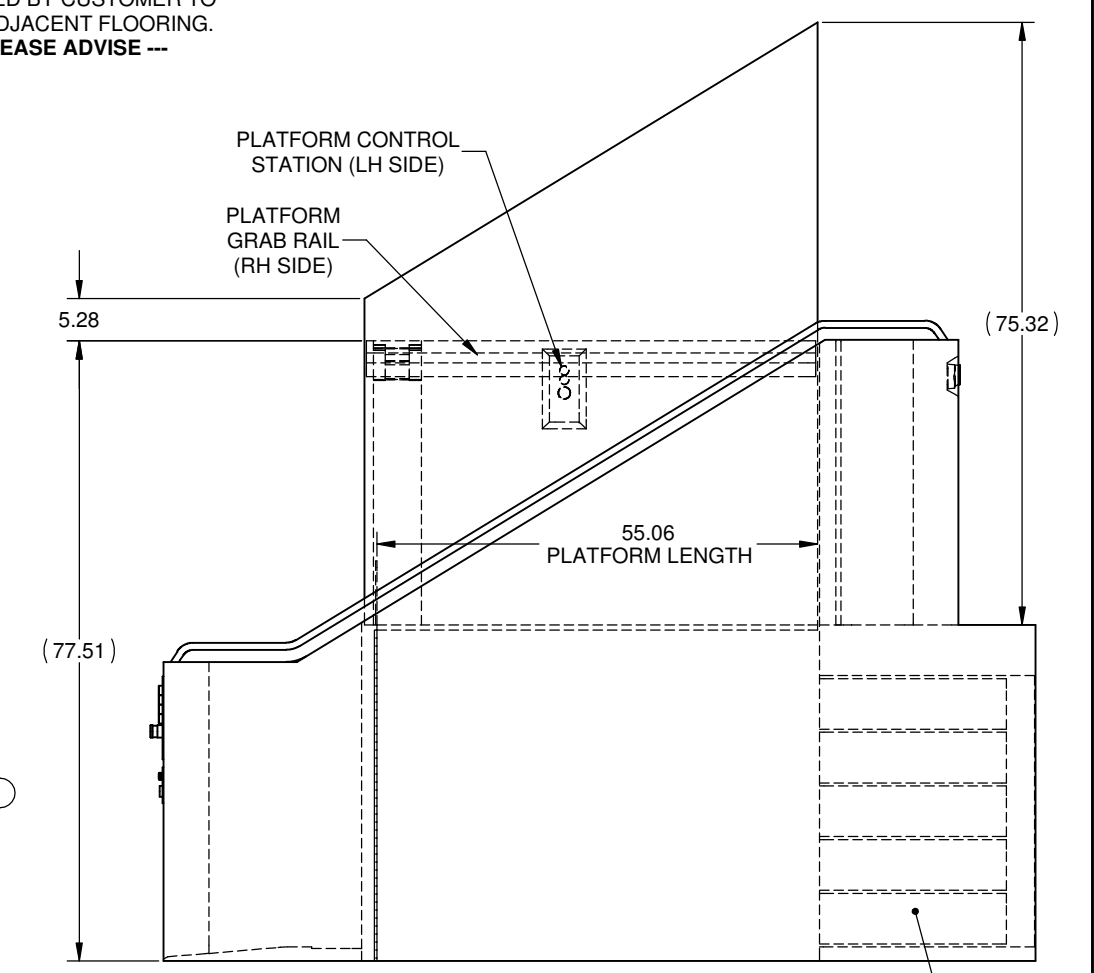
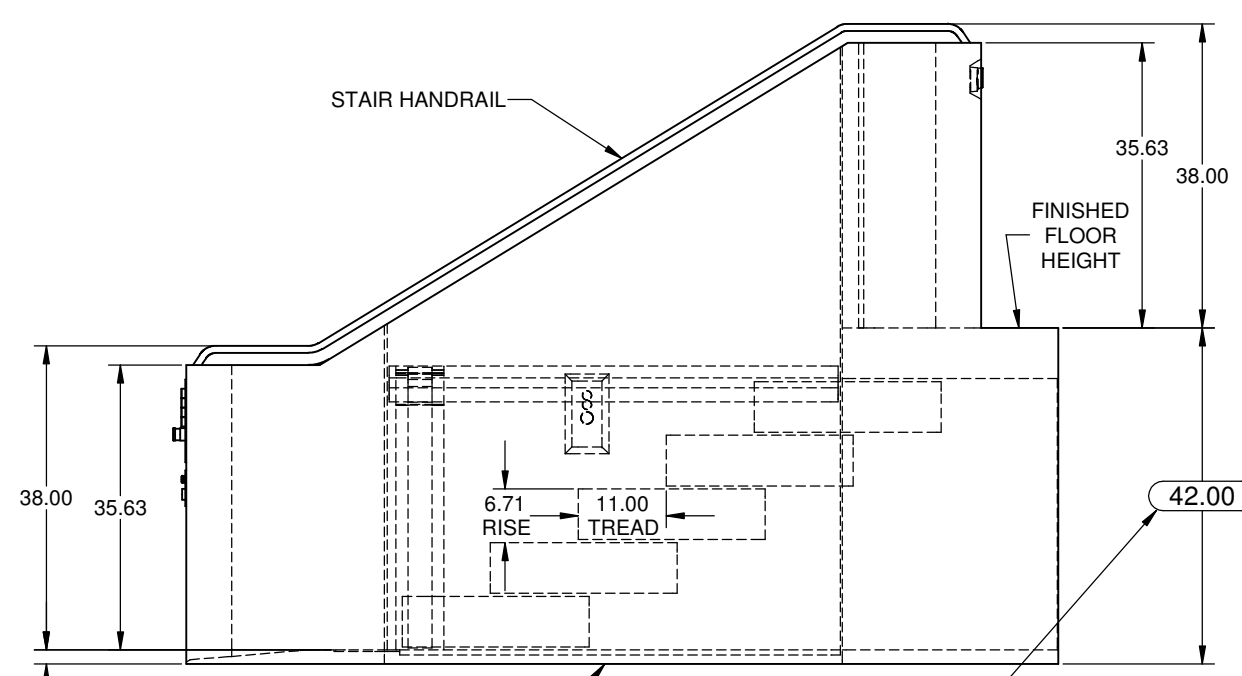
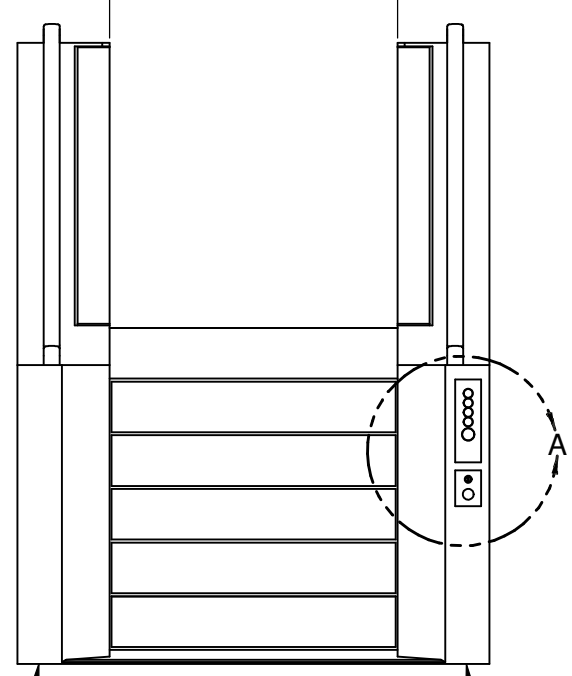

**ELEVATION VIEW
LIFT PLATFORM AT UPPER LANDING**

**ELEVATION VIEW
STEPS CONFIGURATION**

DRAWING CERTIFICATION

CUSTOMER:
APPROVAL SIGNATURE:
DATE:
PROJECT NAME:
PROJECT LOCATION:
DRAWING REV: A

APPROVAL NOTE:
**CONTRACTOR MUST VERIFY LANDING HEIGHT
 PRIOR TO RELEASE FOR FABRICATION.
 MEASUREMENT TO BE TAKEN FROM BASE FLOOR AT
 THE LOWER LANDING TO THE FINISH FLOOR AT THE UPPER
 LANDING. SEE DETAILS ON SHEET 3 OF 3.**

LIFT-U
 P.O. BOX 398
 ESCALON, CA. 95320
 209-838-2400

A DIVISION OF
HOGAN MFG., INC.

THIS DOCUMENT IS AND CONTAINS CONFIDENTIAL TRADE SECRET INFORMATION OF THE COMPANY. NO PART OF IT MAY BE REPRODUCED, STORED IN A RETRIEVAL SYSTEM, OR TRANSMITTED IN ANY FORM OR BY ANY MEANS ELECTRONICALLY, PHOTOCOPIING, RECORDING OR OTHERWISE, WITHOUT THE PRIOR WRITTEN PERMISSION OF HOGAN MFG., INC. THIS DOCUMENT IS LOANED FOR THE LIMITED PURPOSES STATED HEREIN ONLY, AND REMAINS THE PROPERTY OF THE COMPANY.

TITLE	LIFT CONFIGURATION		
DOCUMENT NO.	VMH-08-42	SHEET NO.	1 OF 3
REVISION			A

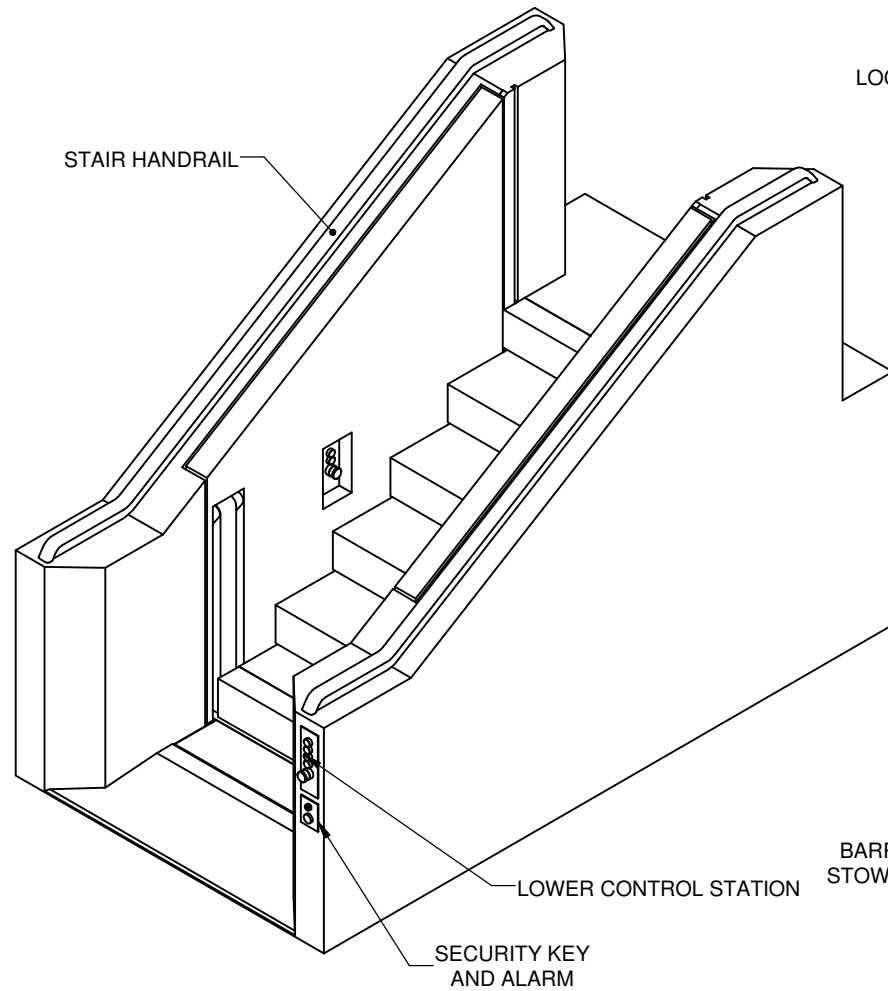

STEPS CONFIGURATION

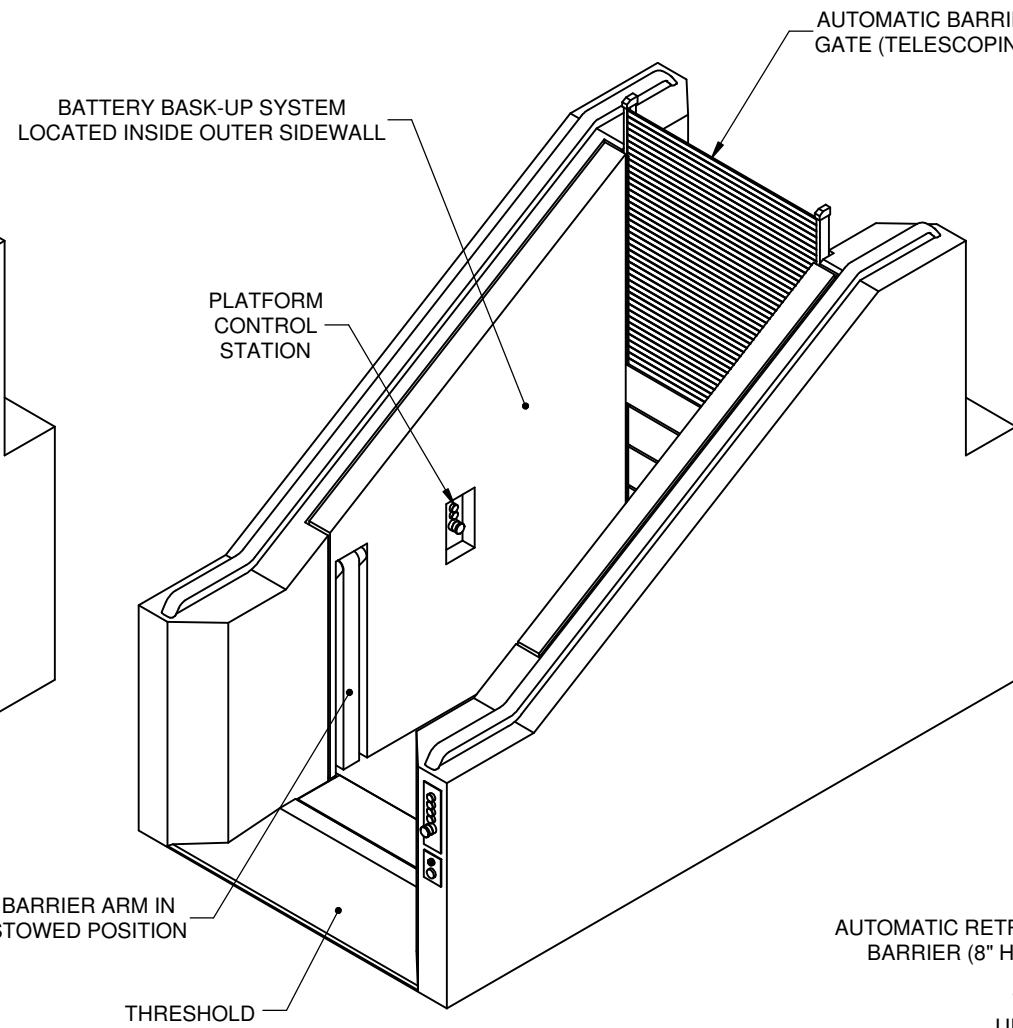

**STEPS RETRACTED
READY FOR PASSENGER INGRESS OR EGRESS**

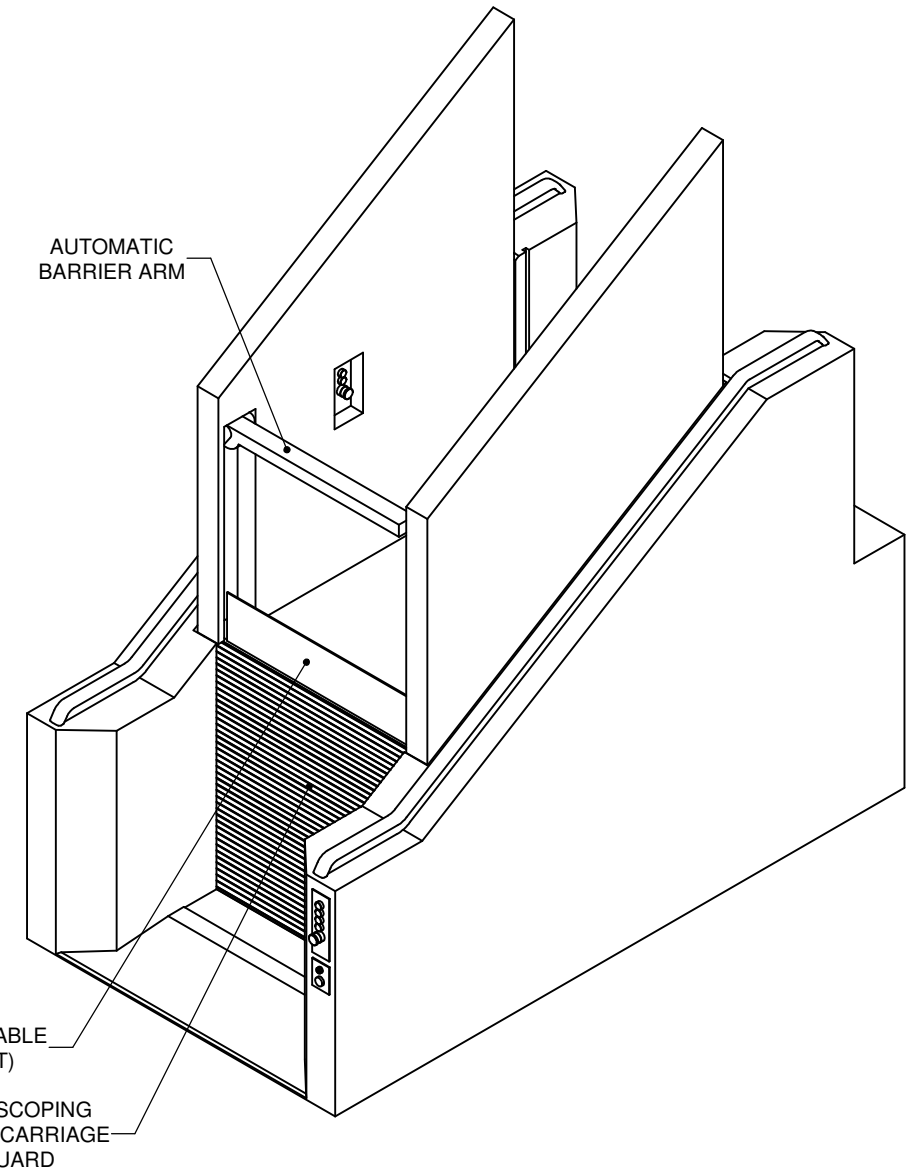

**LIFT PLATFORM AT UPPER LANDING
READY FOR PASSENGER INGRESS OR EGRESS**

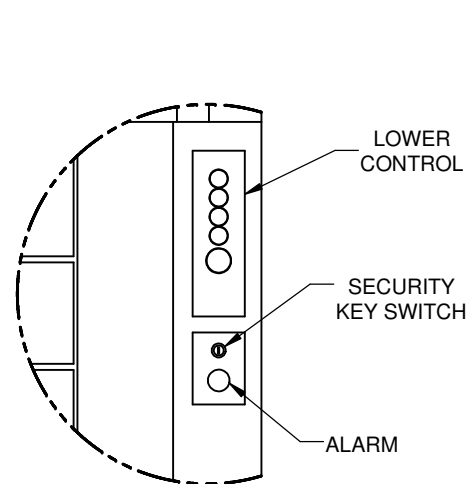

DETAIL A

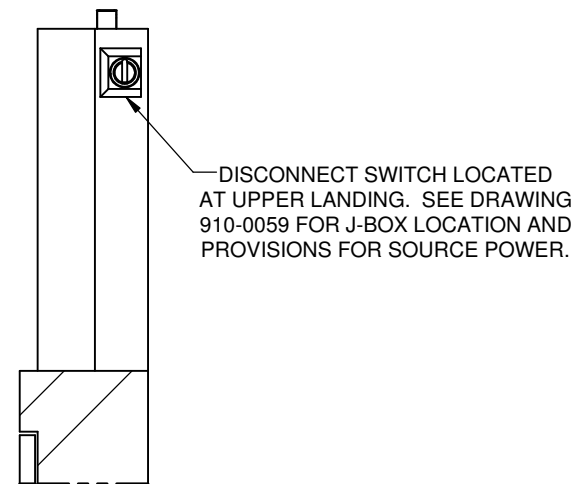

**SECTION B-B
VIEW ROTATED FOR CLARITY**

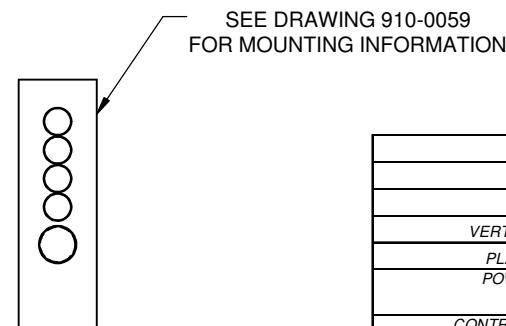

**UPPER CONTROLS STATION
REFERENCE ONLY**

LIFT SPECIFICATIONS	
SPEED:	10 FT/MINUTE MAXIMUM
DRIVE:	2 ACME SCREW JACKS
CAPACITY:	750 LBS. MAX. OPERATING LOAD
VERTICAL TRAVEL:	42 IN.
PLATFORM DIMS:	36 IN. x 55 IN. USEABLE
POWER SOURCE:	208/230 VOLT, 20 AMP, 3 WIRE SINGLE PHASE
CONTROL STATIONS:	LOWER LEVEL AND PLATFORM - LIFT MOUNTED; UPPER CONTROL SHIPPED LOOSE FOR WALL MOUNTING BY OTHERS
EMERGENCY POWER:	BATTERY BACK-UP (UPS) INCLUDED
MANUAL OPERATION:	LOWERING MEANS PROVIDED
EXTERIOR FINISH:	STANDARD TEXTURED

LIFT-U
P.O. BOX 398
ESCALON, CA. 95320
209-838-2400

A DIVISION OF
HOGAN MFG., INC.

THIS DOCUMENT IS AND CONTAINS CONFIDENTIAL TRADE SECRET INFORMATION OF THE COMPANY. NO PART OF IT MAY BE REPRODUCED, STORED IN A RETRIEVAL SYSTEM, OR TRANSMITTED IN ANY FORM OR BY ANY MEANS ELECTRONICALLY, PHOTOCOPIING, RECORDING OR OTHERWISE, WITHOUT THE PRIOR WRITTEN PERMISSION OF HOGAN MFG, INC. THIS DOCUMENT IS LOANED FOR THE LIMITED PURPOSES STATED HEREIN ONLY, AND REMAINS THE PROPERTY OF THE COMPANY.

TITLE		LIFT CONFIGURATION	
DOCUMENT NO.	VMH-08-42	SHEET NO.	2 OF 3
		REVISION	A

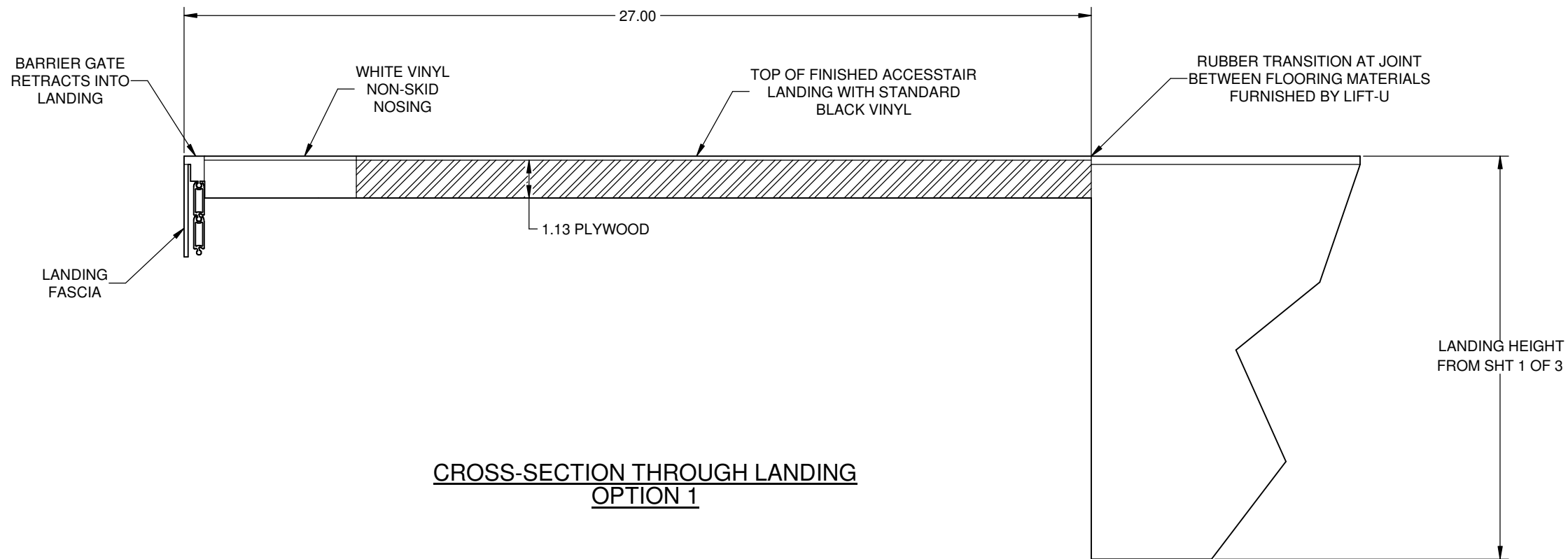

CROSS-SECTION THROUGH LANDING
OPTION 1

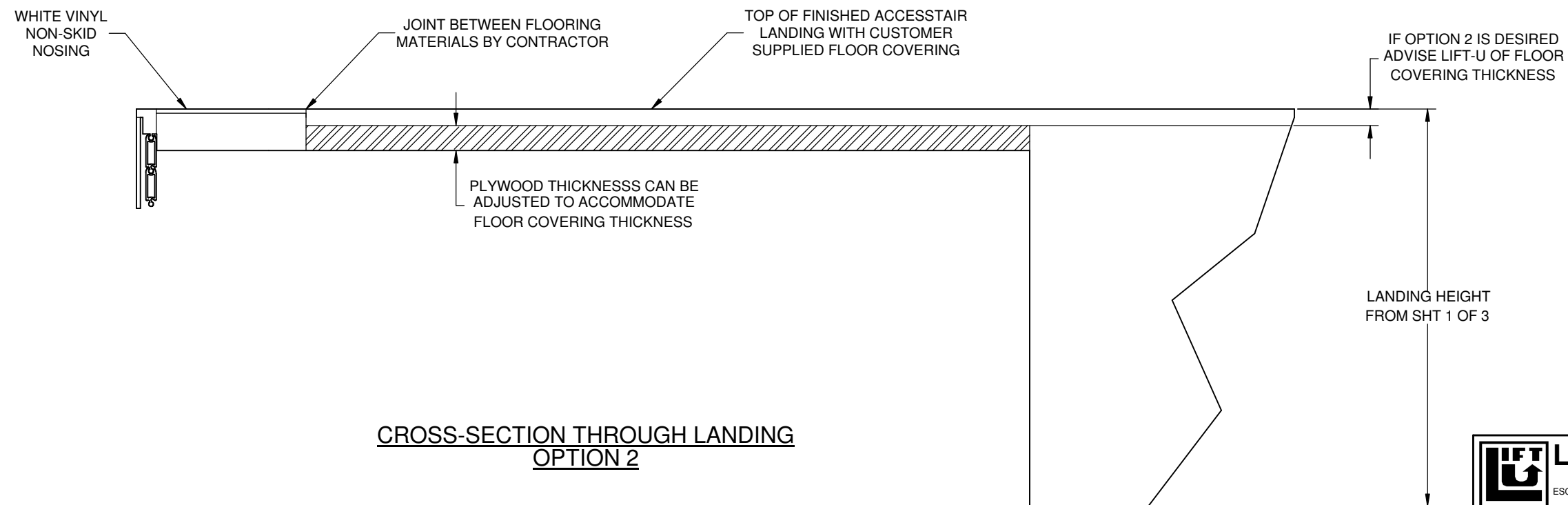

CROSS-SECTION THROUGH LANDING
OPTION 2

 LIFT-U P.O. BOX 398 ESCALON, CA. 95320 209-838-2400	THIS DOCUMENT IS AND CONTAINS CONFIDENTIAL TRADE SECRET INFORMATION OF THE COMPANY. NO PART OF IT MAY BE REPRODUCED, STORED IN A RETRIEVAL SYSTEM, OR TRANSMITTED IN ANY FORM OR BY ANY MEANS ELECTRONICALLY, PHOTOCOPYING, RECORDING OR OTHERWISE, WITHOUT THE PRIOR WRITTEN PERMISSION OF HOGAN MFG., INC. THIS DOCUMENT IS LOANED FOR THE LIMITED PURPOSES STATED HEREIN ONLY, AND REMAINS THE PROPERTY OF THE COMPANY.	
	A DIVISION OF HOGAN MFG., INC.	
TITLE LIFT CONFIGURATION		
DOCUMENT NO. VMH-08-42	SHEET NO. 3 OF 3	REVISION A