

| REVISIONS | | | | | | | | | |
|-----------|-----|------|------|--|------|------------|------|------|--|
| LTR | ECO | APPD | DATE | DESCRIPTION | DFTR | DATE | CHKR | DATE | |
| A | | | | RELEASED | CAL | 3/13/2009 | | | |
| B | | | | ADDED 60" TURNING SPACE, NOTES & SHEET 2 | BSA | 10/18/2011 | | | |

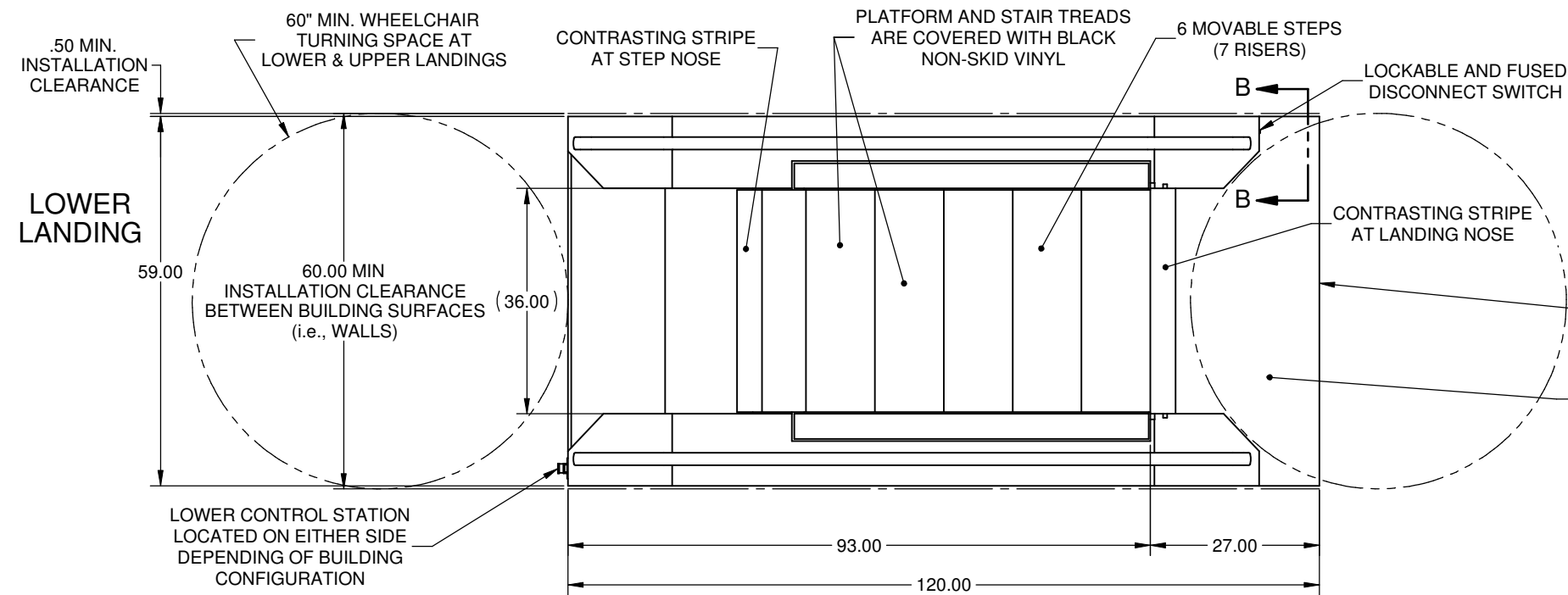

- NOTES:**
1. THIS DRAWING IS SUBJECT TO CHANGE PENDING APPLICABLE STATE AND LOCAL CODES, AND CUSTOMER APPROVAL.
 2. CUSTOMER MUST PROVIDE APPLICABLE STATE AND LOCAL CODES TO LIFT-U PRIOR TO DESIGN.
 3. DRAWING MUST BE SIGNED BY CUSTOMER AND RETURNED TO LIFT-U PRIOR TO PRODUCTION RELEASE. CUSTOMER APPROVAL SIGNIFIES THAT ALL DIMENSIONS ARE CORRECT TO THEIR SPECIFICATIONS.
 4. SEE SHEET 2 OF 3 FOR LIFT SPECIFICATIONS.

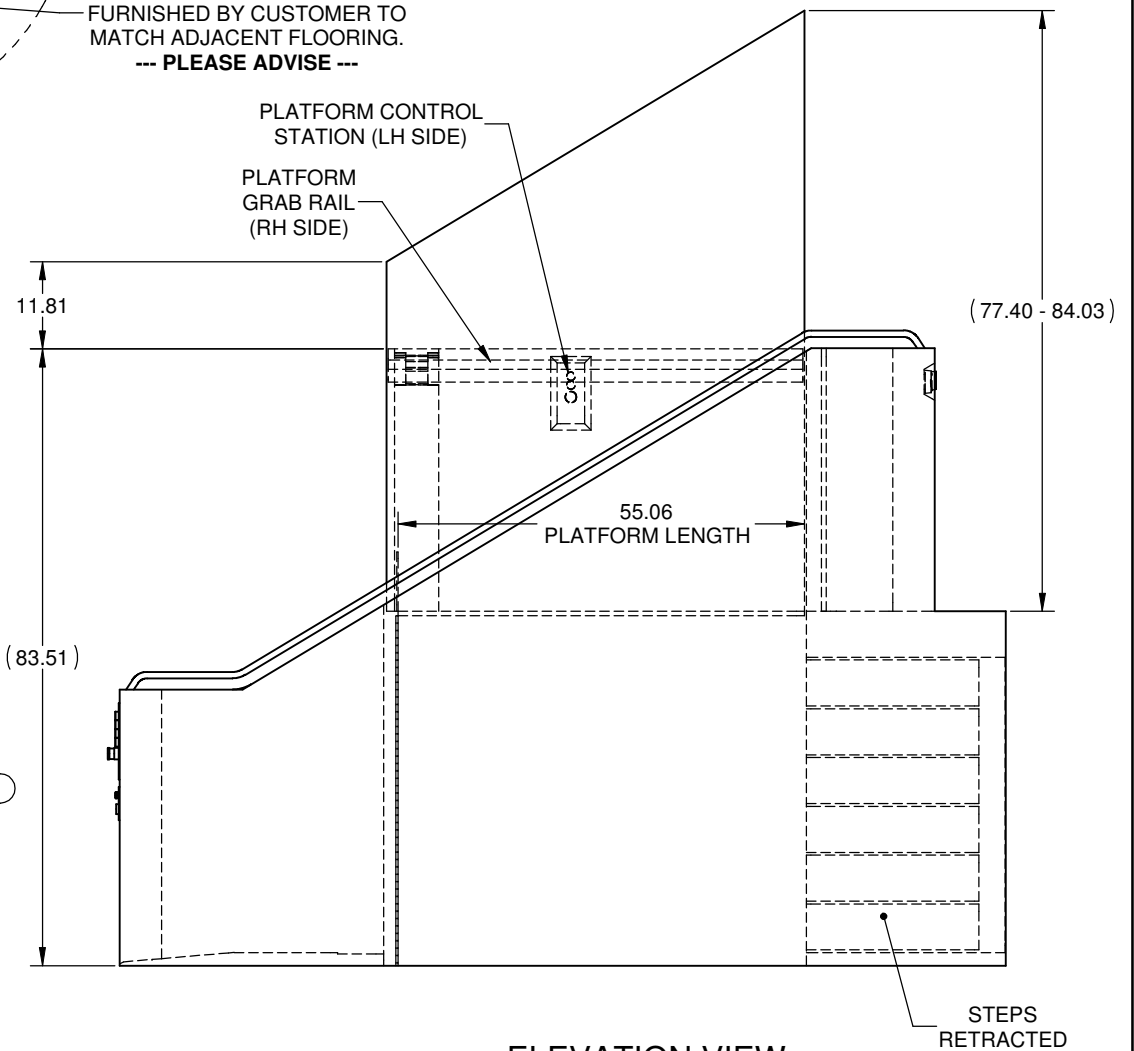
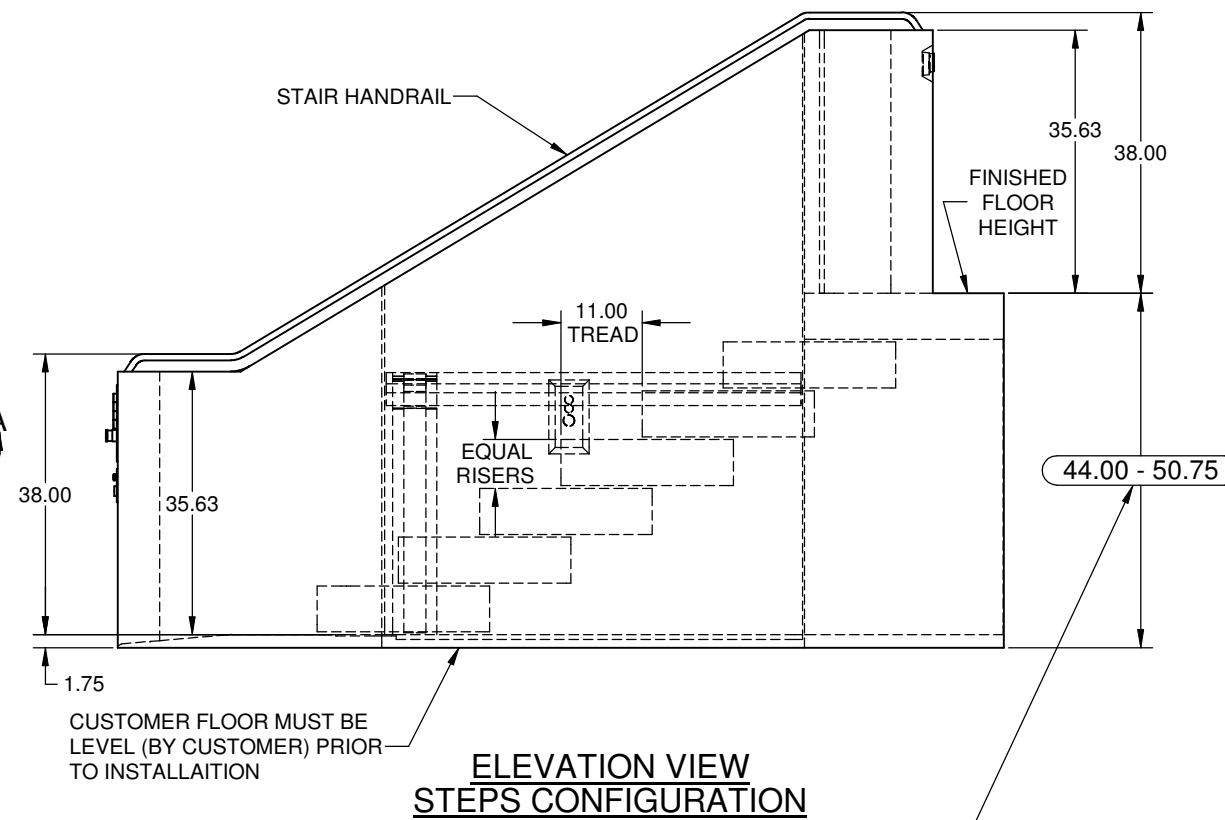
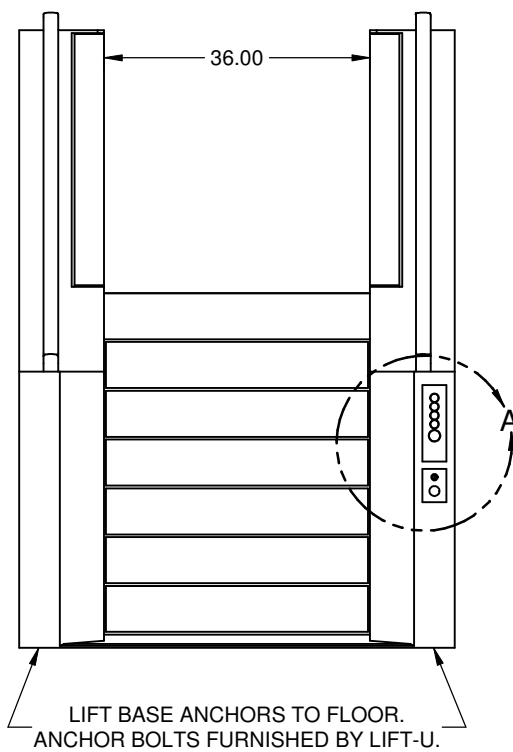

APPROVAL NOTE:
CONTRACTOR MUST VERIFY LANDING HEIGHT PRIOR TO RELEASE FOR FABRICATION. MEASUREMENT TO BE TAKEN FROM BASE FLOOR AT THE LOWER LANDING TO THE FINISH FLOOR AT THE UPPER LANDING.

| | | |
|--|---|--------------------------|
| <p>LIFT-U P.O. BOX 398 ESCALON, CA. 95320 209-838-2400</p> | <p>THIS DOCUMENT IS AND CONTAINS CONFIDENTIAL TRADE SECRET INFORMATION OF THE COMPANY. NO PART OF IT MAY BE REPRODUCED, STORED IN A RETRIEVAL SYSTEM, OR TRANSMITTED IN ANY FORM OR BY ANY MEANS ELECTRONICALLY, PHOTOCOPYING, RECORDING OR OTHERWISE, WITHOUT THE PRIOR WRITTEN PERMISSION OF HOGAN MFG., INC. THIS DOCUMENT IS LOANED FOR THE LIMITED PURPOSES STATED HEREIN ONLY, AND REMAINS THE PROPERTY OF THE COMPANY.</p> | |
| | <p>A DIVISION OF HOGAN MFG., INC.</p> | |
| <p>TITLE LIFT CONFIGURATION, 6-STEP</p> | | |
| <p>DOCUMENT NO. 910-0084</p> | <p>SHEET NO. 1 OF 2</p> | <p>REVISION B</p> |

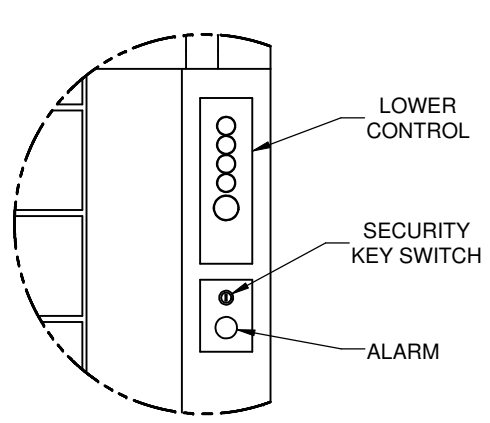
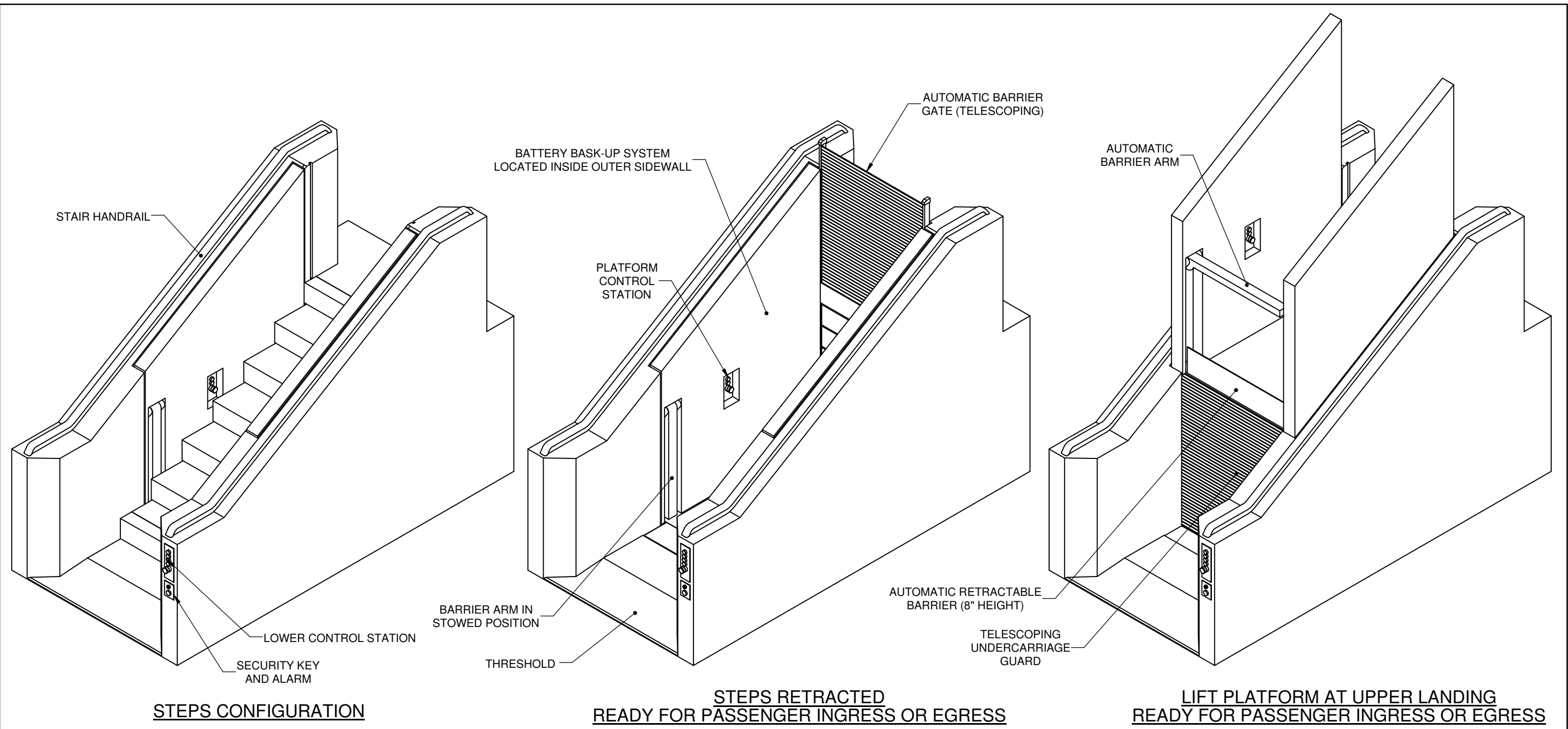

DETAIL A

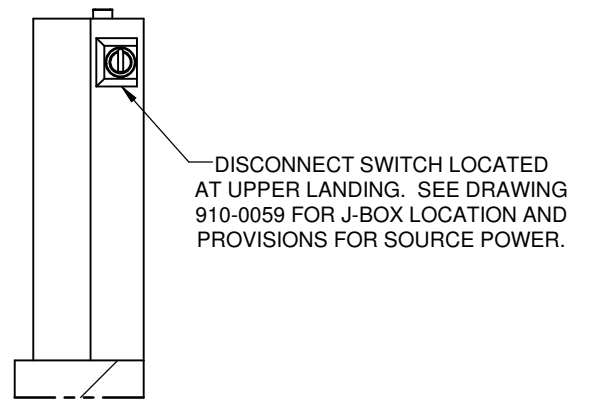

**SECTION B-B
VIEW ROTATED FOR CLARITY**

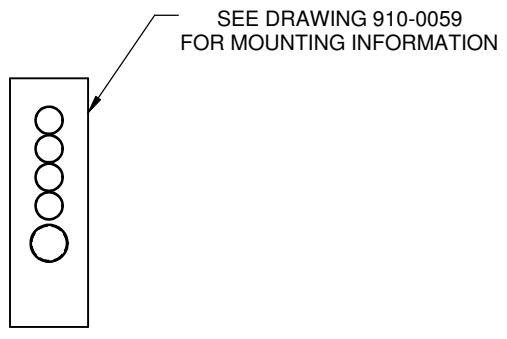

**UPPER CONTROLS STATION
REFERENCE ONLY**

LIFT-U
 P.O. BOX 398
 ESCALON, CA. 95320
 209-838-2400

A DIVISION OF
HOGAN MFG., INC.

THIS DOCUMENT IS AND CONTAINS CONFIDENTIAL TRADE SECRET INFORMATION OF THE COMPANY. NO PART OF IT MAY BE REPRODUCED, STORED IN A RETRIEVAL SYSTEM, OR TRANSMITTED IN ANY FORM OR BY ANY MEANS ELECTRONICALLY, PHOTOCOPYING, RECORDING OR OTHERWISE, WITHOUT THE PRIOR WRITTEN PERMISSION OF HOGAN MFG., INC. THIS DOCUMENT IS LOANED FOR THE LIMITED PURPOSES STATED HEREIN ONLY, AND REMAINS THE PROPERTY OF THE COMPANY.

| | | | |
|--------------|----------------------------|-----------|--------|
| TITLE | LIFT CONFIGURATION, 6-STEP | | |
| DOCUMENT NO. | 910-0084 | SHEET NO. | 2 OF 2 |
| | | REVISION | B |